



RCT POWER 10KW RESIDENTIAL ENERGY STORAGE SYSTEM SOLUTION

SMART STORAGE FOR A GREENER AND BRIGHTER FUTURE



high efficiency



back-up power supply



quick and easy installation



everything needed from one source

RCT POWER BATTERY 9.6 kWh

- Article Nr. 220-0001
- Modular high-voltage battery for PV storage system
- 5x battery modules of 1.92 kWh each

BATTERY INVERTER POWER STORAGE DC 10.0 kW

- Article Nr. DC 8.0 110-0003
- Article Nr. DC 10.0 110-0004
- Grid-connected storage inverter for residential and commercial PV systems

BACKUP POWER FOR DC STORAGE SYSTEMS | RCT POWER SWITCH

- Article Nr. 310-0003
- Ensures the functionality of the PV system during a power outage

RCT POWER RESS SYSTEM COMPONENTS

- 1x Power Switch Incl. Back-up Power
- 1x Power Storage Inverter
- 5x Battery 1.92 kWh = 9.6 kWh
- 1x Battery BMS Master Unit



Test Winner 5 & 10 kW Storage Systems

POWER STORAGE DC

8.0 | 10.0

DC-COUPLED HYBRID INVERTER FOR RESIDENTIAL AND COMMERCIAL PV SYSTEMS



high efficiency



up to 2 roof orientations



quick and easy installation



everything needed from one source

HIGH EFFICIENCY

- Two independent MPP-trackers, switchable to parallel mode
- European efficiency > 98 %
- Input for high voltage battery
- Suitable for dynamic power adjustment
- Intelligent energy storage management with forecast based charging
- Exact and fast control behaviour

UNIQUE FLEXIBILITY

- 3-phase feed-in
- Wide MPP range for flexible string planning and easy repowering
- Max-Power Control - self-learning shade management
- Cascadable, expandable and combinable with existing PV-systems
- Hybrid-ready charging of the battery also with external AC sources
- Emergency power capability in conjunction with the RCT Power Switch
- Simple design with the RCT Power Designer - design tool

EASY INSTALLATION

- DC and AC connection with plug & play
- Integrated RCT Power APP solution
- No Internet access required for setup

USER FRIENDLY COMMUNICATION

- Multi-information LCD-display
- LAN and WLAN
- RCT Power Portal for user-friendly system monitoring
- Multi-function communication board for connection of various devices
- Suitable for wallbox chargers, heating elements, heat pumps and energy management systems

INNOVATIVE DESIGN

- Silent, maintenance free cooling
- Durable aluminium housing
- With 32 kg a lightweight in its category
- IP42 protection - suitable for indoor installation

BLOCK DIAGRAM

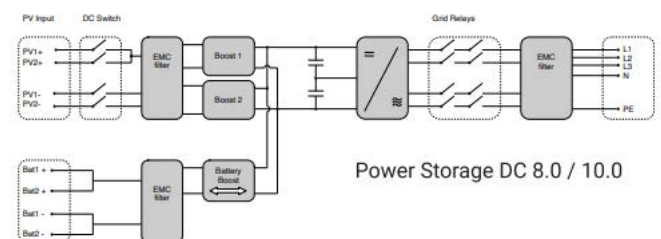

POWER STORAGE DC

8.0**10.0**

BATTERY

DC voltage range	120V ... 600V	120V ... 600V
Max. charging / discharging current	25A / 25A	25A / 25A
Max. charging / discharging power	N/A	N/A
Plug type	Weidmüller PV Stick	
Battery tower connections	2	2

DC INPUT

Max. recommended DC Power (south / east-west)*	10,8 kW / 12 kW	13,5 kW / 15 kW
MPPT	2 (can be connected in parallel)	
Input per MPPT	1	
Max. module current (Impp)	15,5 A	15,5 A
Max. DC current per MPPT	14 A	14 A
Max. short-circuit current PV input (Iscmax)	18 A	18 A
DC rated voltage	700 V	700 V
DC starting voltage	150 V / 40 W	
DC voltage range	140 V ... 1000 V	
MPP voltage range	380 V ... 800 V	380 V ... 800 V
Max. DC voltage	1000 V	
Plug type	Weidmüller PV Stick	

AC OUTPUT (Grid operation)

AC rated power	8000 W	9900 W
Max. active power	8000 W	9900 W
Max. apparent power	10500 VA	10500 VA
Nominal AC current per phase	11,6 A	14,5 A
Max. AC current per phase	15,2 A	15,2 A
Rated frequency	50 Hz / 60 Hz	50 Hz / 60 Hz
Frequency range	45 Hz ... 65 Hz	45 Hz ... 65 Hz
Max. inrush current	15,2 A, 01, ms	15,2 A, 0,1 ms
Max. residual current (RMS)	285 mA	
AC rated voltage	230 V / 400 V (L1, L2, L3, N, PE)	
AC rated voltage range	180 V ... 290 V	
Distortion factor	< 2 % at rated power	
Reactive power factor	1 (setting range 0,8 cap ... 0,8 ind)	
Protection against island operation	yes	
Earth fault monitoring	RCD	
DC current feed	< 0,5 In	
Necessary phases, grid connections	3 (L1, L2, L3, N, PE)	
Number of feed-in phases	3	
Mains voltage monitoring	N/A	N/A
AC connection	spring loaded clamps	spring loaded clamps

PERFORMANCE DATA

Self-consumption	6,0 W	6,0 W
Max. efficiency PV2AC	98,60 %	98,60 %
European efficiency PV2AC	98,33 %	98,35 %
Average efficiency PV2AC	97,78 %	97,89 %
Average efficiency PV2Bat	98,00 %	98,00 %
Average efficiency AC2Bat	97,33 %	97,44 %
Average efficiency Bat2AC	97,36 %	97,48 %
Mean dead time / settling time	0,1 s / 0,4 s	0,1 s / 0,4 s
Round trip efficiency	N/A	N/A
Topology	transformerless	

GENERAL

PV-DC load break switch	integrated	
DC overvoltage category	II	
AC overvoltage category	III	
Display	LCD dot matrix 1218 x 64 illuminated	
Cooling power electronics	free convection	
IP protection class	42	
Ambient temperature range	-25°C ... 50°C (40°C at full load)	
Max. relative humidity	5 - 85 % (non-condensing)	
Typical noise level	≤ 35 dB	
Type of installation	wall mounting	
Max. installation height above sea level	2000 m	
Dimensions (width x height x depth)	585 x 570 x 200 mm	585 x 570 x 200 mm
Weight	32 kg	32 kg

COMMUNICATION / INTERFACES / STANDARDS

Communication interfaces	Wi-Fi, Ethernet, RS485, MFR, 4 x digital in, 2 x digital in/out	
Protection class	1	
Overload behavior	operating point shift	
Safety	EN/IEC62109-1, EN/IEC621090/2	
Public grid	VDE-AR-N 4105:2018-11, EN 50549	
EMC	EN61000-6-2, EN61000-6-3, EN61000-3-2, EN61000-3-3	

* Depending on orientation, inclination and location of the installation



Test Winner 5 & 10 kW Storage Systems

POWER BATTERY

3.8 | 5.7 | 7.6 | 9.6 | 11.5

MODULAR HIGH VOLTAGE BATTERY FOR PV STORAGE SYSTEMS



environmentally friendly and safe LiFePO₄ battery



modular space saving design



easy to transport and install



everything needed from one source

HIGH EFFICIENCY

- LiFePO₄ technology
- 25 A charge & discharge capability
- High voltage, high efficiency, low stress operation
- Modern and space-saving design

EASY INSTALLATION

- Modular concept and simple wiring for easy transport and installation
- All components are lighter than 25 kg
- Optimised, German battery management system
- Plug & play

MONITORING VIA APP

- Powerful RCT Power App
- Full data visualization
- Monitoring from every location
- Configuration options
- One click update

FLEXIBLE AND UPGRADEABLE

- 2 - 6 battery stacks per battery tower
- Scalable battery capacity (with 1.92 kWh stacks each)
- upgrade to double tower (DT) configuration up to 23.0 kWh
- Suitable for back-up systems

SUSTAINABLE

- Lithium-iron-phosphate cell chemistry

BLOCK DIAGRAM

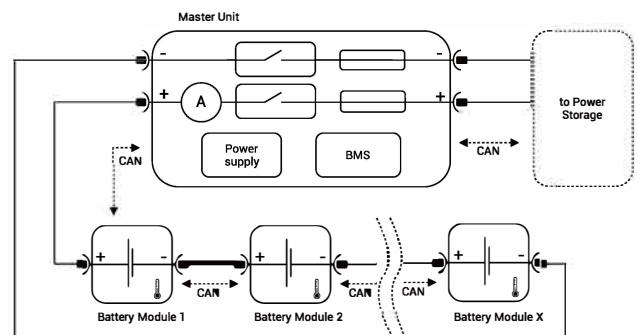

POWER BATTERY

3.8

5.7

7.6

9.6

11.5

ELECTRICAL PARAMETERS

Nominal capacity (at 25°)	3,84 kWh	5,76 kWh	7,68 kWh	9,60 kWh	11,52 kWh
Usable capacity (90% DoD)	3,46 kWh	5,18 kWh	6,91 kWh	8,64 kWh	10,37 kWh
Voltage range	120 V ~ 173 V	180 V ~ 260 V	240 V ~ 346 V	300 V ~ 432 V	360 V ~ 520 V
Nominal voltage	154 V	230 V	307 V	384 V	461 V
Maximum charge / discharge current	25 A / 25 A	25 A / 25 A	25 A / 25 A	25 A / 25 A	25 A / 25 A
Standby consumption	< 5 W				

INTERFACES

Power Storage interface	CAN
-------------------------	-----

GENERAL

Battery technology	LiFePO ₄				
Dimensions (height x width x depth) (mm)	600x340x340	830x340x340	1060x340x340	1290x340x340	1520x340x340
Weight (single module 24kg)	54 kg	78 kg	102 kg	126 kg	150 kg
Number of battery units	2	3	4	5	6
IP degree of protection	IP42				
Type of installation	floor stand / indoor				
Operating temperature range	-15 °C ~ +40 °C				
Connector type	Weidmüller PV-Stick				

SAFETY / STANDARDS

Safety class	I
Certificates	UN 38-3, EN/IEC 62619, EN/IEC 62133
EMC	EN61000-6-2, EN61000-6-3, EN61000 – 4 -2 , -3, -4, -8
Safety	EN/IEC 61010-1:2010

**POWER UP.
SCALE UP.
COST DOWN.**



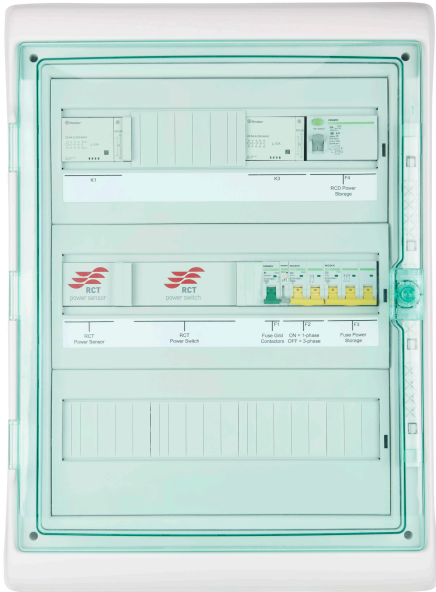

POWER SWITCH FOR STORAGE DC

8.0 | 10.0

SAFE SUPPLY OF HOUSEHOLD AND FUNCTIONAL RELIABILITY OF PV SYSTEM IN CASE OF GRID FAILURE



BACKUP POWER SUPPLY

- Provision of backup grid
- 3-phase supply
- Separated output for not backedup loads

EASY INSTALLATION

- Compact and lightweight housing
- Power Sensor included
- Wall mounting
- Upgradeable

EFFICIENT

- Up to 6 kVA in single or 3-phase mode for Power Storage DC 6.0
- Up to 10 kVA in 3-phase backup mode for Storage DC 8.0 and 10.0
- Fast switching

SYSTEM OVERVIEW

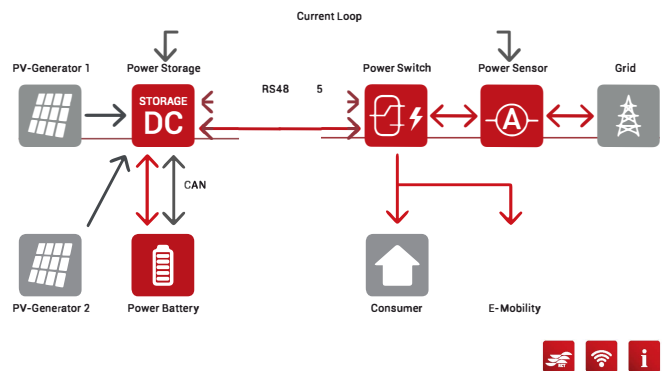

POWER DATA

Nominal voltage	230/400 VAC
Nominal frequency	50 Hz
Max. prospective short circuit current	10 kA
Max. grid-side fuse	63 A
Max. thermal throughput power (3AC) PNOM	30 kW (Ta = 25°) / 20 kW (Ta = 40°)
Losses in standby-mode	app. 15 W
Operating losses at 5/10/20/30kW and full feed in of the Power Storage DC	app. 5/8/20/38 W
Allowed battery inverters	RCT Power Storage DC 4.0 /6.0 / 8.0 / 10.0
Disconnection from the grid	4-pole
Permitted grid form	TN-C-S/TN-S/TT
FRT support	no
Fuse connection RCT Power Storage	MCCB-3C25
Terminals meter/load/backup load	spring clamps up to 16mm ²
Terminals Power Storage	spring clamps up to 6mm ²

OTHERS

Operating temperature range	-5°C ... +40 °C
Relative humidity	5 ... 95 %
Type of installation	wall mounting
Dimensions (height x width x depth)	448 x 610 x 160 mm
Weight app.	15 kg

SAFETY / STANDARDS

Protection class [EN 61140]	
IP protection class [EN 60529]	65
2014/35/EU Annex III	yes
IEC/EN61439-1 (DE: VDE 0660-600-1)	yes
IEC/EN61439-2 (DE: VDE 0660-600-2)	yes
IEC/EN61439-3 (DE: VDE 0660-600-3)	yes
VDE-AR-E-2510-2	yes
TOR generator - Type A	no
OVE guideline R20:2016	no
Warranty	2 years

WHAT IS RCT BACKUP POWER?

In the event of a power failure, the RCT Power Switch ensures that the PV system and connected battery storage unit keep operational. The RCT Power Switch disconnects the domestic network from the mains supply (TN-C-S/TN-S or TT). It then creates a stand-alone grid in combination with the DC-connected RCT Power storage system.

To optimise the security of supply, the RCT Power Switch is equipped with two outputs: one for loads that should continue to be supplied with backup power and one for loads that can be dispensed in the event of a power failure

An additional RCT Power Sensor is not required.

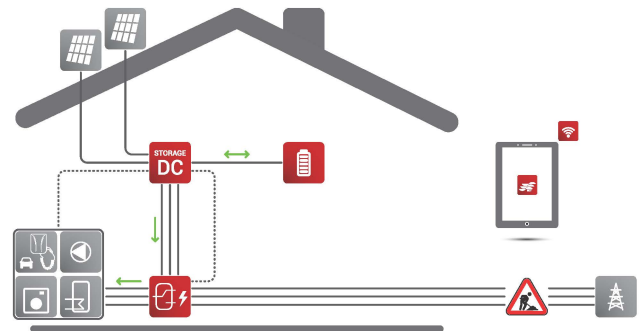

- Automatic switching in case of power failure
- Switch-on delay of 5-10 seconds
- Battery and PV system can be used as energy source
- Battery can be recharged from PV system and thus the backup system can supply power for several days