



PV Grid-tied Inverter
SPI-B Series (75K-150K)

User Manual

Copyright © Xiamen Kehua Digital Energy Tech Co., Ltd. 2022. All rights reserved.

No part of this document may be reproduced or transmitted in any form or by any means without prior written consent of Xiamen Kehua Digital Energy Tech Co., Ltd.

Trademarks and Permissions



and other Kehua trademarks are the licensed trademarks of Xiamen Kehua Digital Energy Tech Co., Ltd.

All other trademarks and trade names mentioned in this document are the property of their respective holders.

Notice

The purchased products, services and features are stipulated by the contract made between Kehua and the customer. All or part of the products, services and features described in this document may not be within the purchase scope or the usage scope. Unless otherwise specification in the contract, all statements, information, and recommendations in this document are provided “AS IS” without warranties, guarantees or representations of any kind, either express or implied.

The information in this document is subject to change without notice. Every effort has been made in the preparation of this document to ensure accuracy of the contents, but all statements, information, and recommendations in this document do not constitute a warranty of any kind, express or implied.

XIAMEN KEHUA DIGITAL ENERGY TECH CO., LTD.

Address:	Room 208-38, Hengye Building, No. 100 Xiangxing Road, Torch High-tech Zone (Xiang'an) Industrial Zone, Xiamen, China
Website:	www.kehua.com
E-mail:	service@kehua.com
Customer Service Telephone:	400-808-9986
Tel:	0592-5160516
Fax:	0592-5162166

Foreword

Summaries

Thank you for choosing the PV grid-tied inverter (hereinafter referred to as inverter)!

This document gives a description of the inverter, including appearance, features, working principles, installation, electrical connection, operation, maintenance and storage, etc.

Please save the manual after reading, in order to consult in the future.



NOTE

The figures in this manual are just for reference, for details please see the actual product.







Applicable Model

- SPI75K-B
- SPI80K-B
- SPI90K-B
- SPI100K-B
- SPI110K-B
- SPI125K-B
- SPI136K-BHV
- SPI150K-BHV

Symbol Conventions

The manual quotes the safety symbols, these symbols used to prompt users to comply with safety matters during installation, operation and maintenance. Safety symbol meaning as follows.

Symbol	Description
	Alerts you to a high risk hazard that will, if not avoided, result in serious injury or death.

Symbol	Description
	Alerts you to a medium low risk hazard that could, if not avoided, result in moderate or minor injury.
	Alerts you to a low risk hazard that could, if not avoided, result in minor injury.
	Anti-static prompting.
	Be care electric shock prompting.
 TIP	Provides a tip that may help you solve a problem or save time.
 NOTE	Provides additional information to emphasize or supplement important points in the main text.

Product standard: Q/XMHS 003

Contents

1 Safety Description.....	1
1.1 Safety Announcements.....	1
1.1.1 Use Announcements.....	1
1.1.2 PV String Protection	3
1.1.3 ESD Protection.....	3
1.1.4 Grounding Requirements	3
1.1.5 Moistureproof Protection	4
1.1.6 Warning Mark Setting	4
1.1.7 Electrical Connection.....	4
1.1.8 Measurement Under Operation	5
1.2 Operator Requirements	5
2 Overview.....	6
2.1 Product Intro.....	6
2.1.1 Features.....	7
2.1.2 Model Meaning.....	8
2.2 Appearance and Structure	8
2.2.1 Appearance.....	8
2.2.2 Operation Panel.....	9
2.2.3 Bottom Layout	10
2.2.4 Size	12
2.3 Working Principle.....	12
2.4 Communication	12
2.4.1 RS485 Communication	12
2.4.2 WiseSolar+APP.....	13

2.4.3 PLC Communication (Optional).....	14
2.5 PID Function (Optional).....	16
3 Installation.....	18
3.1 Installation Process.....	18
3.2 Installation Tools.....	19
3.3 Selection of Installation Site.....	20
3.3.1 Installation Environment.....	20
3.3.2 Installation Clearance.....	21
3.3.3 Installation Carrier Requirements.....	23
3.3.4 Installation Method.....	23
3.4 Transporting, Unpacking and Checking.....	24
3.4.1 Transporting.....	24
3.4.2 Unpacking and Checking.....	26
3.5 Inverter Installation.....	26
3.5.1 Bracket Installation.....	26
3.5.2 Wall Mounting.....	29
3.6 Electrical Connection.....	33
3.6.1 Safety Announcements.....	33
3.6.2 Wire Requirements.....	34
3.6.3 External Grounding Connection.....	35
3.6.4 AC Output Wiring.....	37
3.6.5 Internal Grounding Connection.....	42
3.6.6 PV String Input Wiring.....	43
3.6.7 Communication Connection.....	48
3.7 Check the Installation.....	50
4 Startup and Shutdown.....	51
4.1 Check Before Startup.....	51
4.2 Start Inverter.....	51
4.3 Shut Down Inverter.....	52

5 Maintenance and Troubleshooting	53
5.1 Maintenance	53
5.1.1 Maintenance Details and Period.....	53
5.1.2 Maintenance Guide	54
5.2 Troubleshooting.....	56
6 Stop Running, Dismantle, Discard Inverter	59
6.1 Stop Running.....	59
6.2 Dismantle the Inverter.....	60
6.3 Discard the Inverter.....	60
7 Package, Transportation, Storage.....	61
7.1 Package	61
7.2 Transportation	61
7.3 Storage	61
A Technical Specifications	62
B Quality Assurance	67
C Acronyms and Abbreviations	69

1 Safety Description

This chapter mainly introduces the safety announcements. Prior to performing any work on the device, please read the user manual carefully, follow the operation and installation instructions and observe all danger, warning and safety information.

1.1 Safety Announcements

This section mainly describes the safety announcements when operation and maintenance. For details, please refer to safety description in relevant chapters.

CAUTION

Before operation, please read the announcements and operation instructions in this section carefully to avoid accident.

The promptings in the user manual, such as "Danger", "Warning", "Caution", etc. don't include all safety announcements. They are just only the supplement of safety announcements when operation.

NOTE

Any device damage caused by violating the general safety operation requirements or safety standards of design, production, and usage will be out of Kehua's guarantee range.

1.1.1 Use Announcements

DANGER

Don't touch terminals or conductors that connected with grid to avoid lethal risk!

 DANGER

There is no operational part inside the inverter. Please do not open the crust of the inverter by yourself, or it may cause electric shock. The device damage caused by illegal operation is out of the guarantee range.

 DANGER

After disconnect the input and output of the inverter, there still has residual energy in the storage capacitor, which may cause electric shock. Do not perform the maintenance until all power sources are switched off for 30 minutes and check that there is no voltage and current in the inverter by the detection equipment.

 WARNING

Please do not put fingers or tools into the rotating fans to avoid human injury or device damage.

 WARNING

The surface temperature of the inverter may reach to 75°C. During running, please don't touch the surface to avoid scald.

 CAUTION

No liquid or other objects are allowed to enter the inverter, or, it may cause inverter damage.

 WARNING

In case of fire, please use dry power fire extinguisher. If using liquid fire extinguisher, it may cause electric shock.

1.1.2 PV String Protection

When install PV string in daytime, it necessary to cover the PV string by light-proof material, or the PV string will generate high voltage under sunshine. If touching PV string accidentally, it may cause electric shock or human injury!



There exists dangerous voltage between the positive and negative of PV string!

When installing the device, make sure that the connection between inverter and PV string has been disconnected completely. And set warning mark in the disconnected position to avoid reconnecting.

1.1.3 ESD Protection



To prevent human electrostatic damaging sensitive components(such as circuit board), make sure that you wear a anti-static wrist strap before touching sensitive components, and the other end is well grounded.

1.1.4 Grounding Requirements



High leakage risk! The inverter must be grounded before wiring. The grounding terminal must be connected to ground, or, there will be the risk of electric shock when touching the inverter.

- When installing, the inverter must be grounded first. When dismantling, the grounding wire must be removed at last.
- Don't damage the grounding conductor.
- The inverter must be connected to protection grounding permanently.
- Before operation, check the electrical connection to ensure the inverter is grounded reliably.

1.1.5 Moistureproof Protection



Moisture invasion may cause inverter damage!

Observe the following items to ensure the inverter works normally.

- When the air humidity is more than 95%, don't open the door of the inverter.
- In the wet or damp weather, don't open the door of the inverter to maintain or repair.

1.1.6 Warning Mark Setting

In order to avoid accident for unwanted person gets close to the inverter or makes improper operation, observe the following requirements while installing, maintaining or repairing.

- Set warning marks where the switches are to avoid switching them on improperly.
- Set warning signs or safety warning belt in the operation area, which is to avoid human injury or device damage.

1.1.7 Electrical Connection

Electrical connection must be performed according to the description in the user manual and the electrical schematic diagram.



The configuration of PV string, grid level, grid frequency, etc. must meet the technical requirements of inverter.

Grid-tied generation should be allowed by the local power supply department and the related operation should be performed by professionals.

All electrical connection must meet the related country and district standard.

1.1.8 Measurement Under Operation



There exists high voltage in the device. If touching device accidentally, it may cause electric shock. So, when perform measurement under operation, it must take protection measure (such as wear insulated gloves, etc.)

The measuring device must meet the following requirements:

- The range and operation requirements of measuring device meets the site requirements.
- The connections for measuring device should be correct and standard to avoid arcing.

1.2 Operator Requirements



The operation and wiring for inverter should be performed by qualified person, which is to ensure that the electrical connection meets the related standards.

The professional technician must meet the following requirements:

- Be trained strictly and understand all safety announcements and master correct operations.
- Fully familiar with the structure and working principle of the whole PV grid-tied generation system.
- Know well about the related standards of local country and district.

2 Overview

This chapter mainly introduces product appearance, structure, working principles and communication method, etc.

2.1 Product Intro

The inverter converts the DC energy from PV string into AC energy and then feedbacks to power grid, which is suitable for the large power station grid-tied system. The PV grid-tied generation system consists of PV string, PV grid-tied inverter, transformer and power distribution system, as shown in Figure2-1.

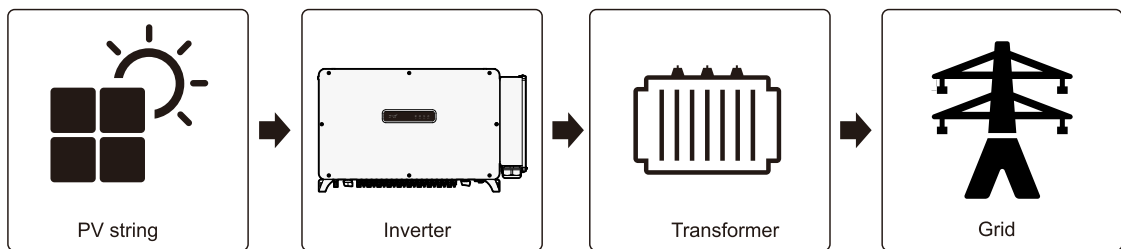

Figure2-1 PV grid-tied generation system



PV grid-tied power generation needs to obtain the permission of local power supply department and performed by professionals.

 **NOTE**

SPI75K-B, SPI80K-B, SPI90K-B, SPI100K-B, SPI110K-B and SPI125K-B support five grid forms, that is TN-S, TN-C, TN-C-S, TT and IT; SPI136K-BHV and SPI150K-BHV support the IT grid form, as shown in Figure2-2.

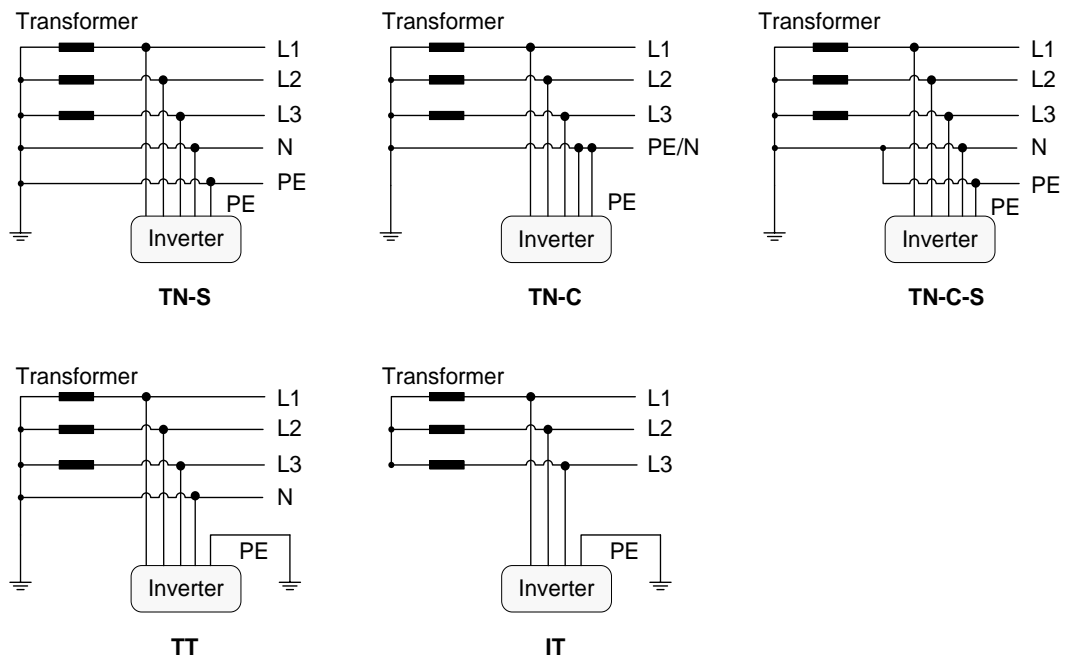

Figure2-2 Grid form

2.1.1 Features

- 1100V high voltage input, increasing efficiency and cost reduction.
- Full voltage adaptation, strong grid support, and adaptability to complex power grid.
- Adjustable reactive power, the range of power factor is -0.8 (lag) $\sim +0.8$ (ahead) .
- Include smart I-V scanning, fault wave capture, remote online upgrade.
- Adopt intelligent fan control and fault detection.
- Various options, such as Anti-PID module, GPRS/WIFI remote APP monitoring, and local WIFI+APP intelligent operation and maintenance, for flexible choice.
- Support PLC communication, night SVG function, friendly grid response, which can save cost for the power station construction.
- Sub-array controller can be selected to quickly response the power station instruction.
- Easy maintenance with bluetooth.
- Adopt the modular design, which is convenient for maintenance. The vulnerable parts can be dismantled easily, and it will save the maintenance cost.
- Perfect protection functions: island protection, high/low voltage ride through, DC reverse protection, AC short circuit protection, leakage current protection, surge protection, etc.

2.1.2 Model Meaning

The model meaning of SPI75K-B, SPI80K-B, SPI90K-B, SPI100K-B, SPI110K-B, SPI125K-B is as shown in Figure2-3.

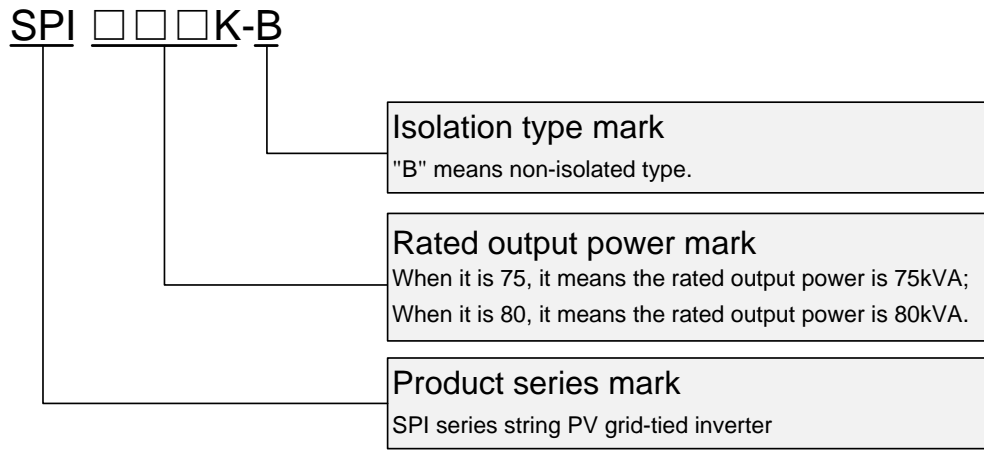

Figure2-3 Model meaning of SPI75K-B, SPI80K-B, SPI90K-B, SPI100K-B, SPI110K-B and SPI125K-B

The model meaning of SPI136K-BHV, SPI150K-BHV is as shown in Figure2-4.

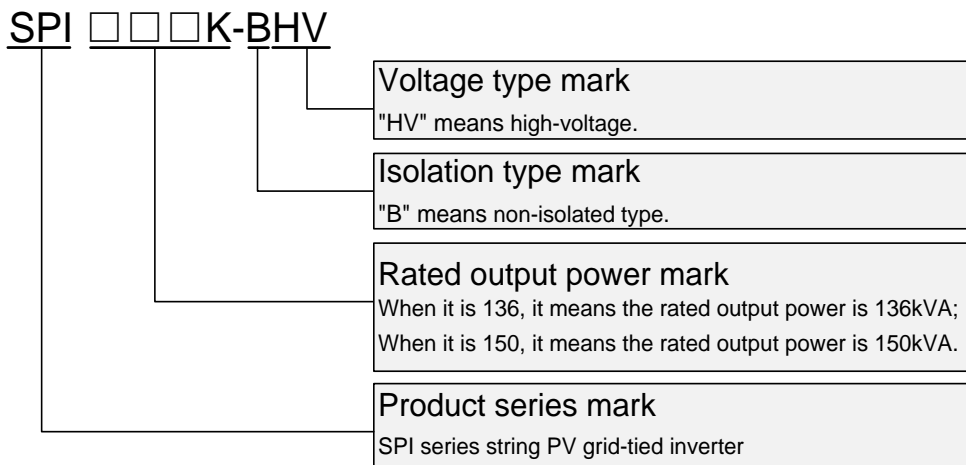

Figure2-4 Model meaning of SPI136K-BHV and SPI150K-BHV

2.2 Appearance and Structure

2.2.1 Appearance

The appearance of SPI-B series (75K-150K) is as shown in Figure2-5.

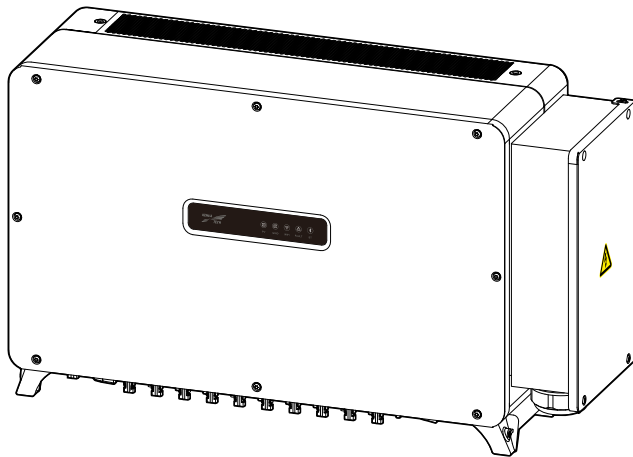

Figure2-5 Appearance

2.2.2 Operation Panel

There are 5 status indicators on the front panel of the inverter, which can indicate the current working status of the inverter. The status of each indicator is shown in Table2-1.

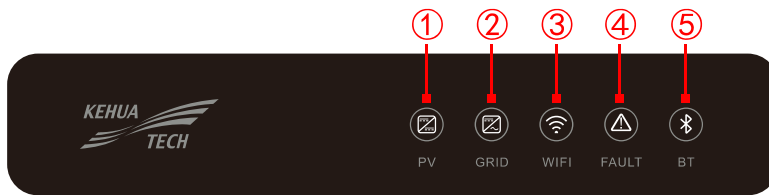

Figure2-6 Operation panel

Table2-1 Indicator status illustration

NO.	Mark	Color	Meaning	Status illustration
①		Green	PV string indicator	ON: At least a group of PV string has been connected.
				Flicker: Night SVG mode grid-tied status.
				OFF: All PV strings are disconnected.
②		Green	Grid indicator	ON: Grid-tied status.
				Flicker: Inverter decreases the rated power.
				OFF: No grid-tied status.
③		Green	WIFI/GPRS	ON: WIFI/ GPRS has been connected.

NO.	Mark	Color	Meaning	Status illustration
			indicator	OFF: WIFI/ GPRS has been disconnected.
④		Red	Fault indicator	ON: The inverter has alarm.
⑤		Green	Bluetooth indicator	ON: Bluetooth has been connected with APP.
				Flicker: Bluetooth has been disconnected with APP.
				OFF: Bluetooth is abnormal.

2.2.3 Bottom Layout

The bottom layout of inverter is as shown in Figure2-7.

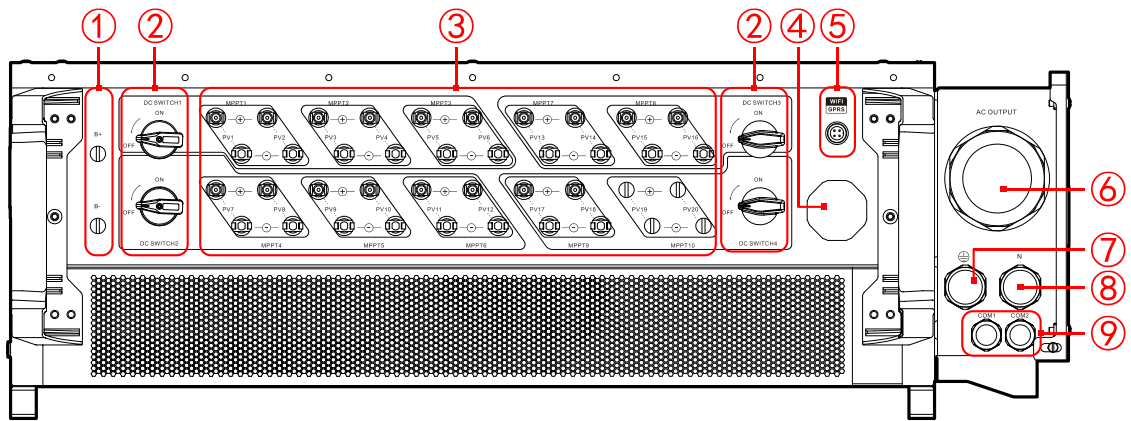



Figure2-7 Bottom layout

NOTE

The SPI136K-BHV, SPI150K-BHV have 10 routes MPPT, the SPI75K-B, SPI80K-B, SPI90K-B, SPI100K-B, SPI110K-B, SPI125K-B have 9 routes MPPT, for details refers to **A Technical Specifications**. If there is no special explanation, the following we will take SPI125K-B as an example to explain.

Table2-2 Bottom layout illustration

NO.	Mark	Name	Remarks
①	B+/B-	Energy storage interface (reserved)	Connect battery.

NO.	Mark	Name	Remarks
②	DC SWITCH	DC switch	DC switch connects inverter with PV string. Each DC switch controls the PV strings in the corresponding marked area.
③	MPPT n+ /MPPT n-	PV string terminal	Connect PV string.
④	-	Breather valve	Adjust the pressure difference of inverter.
⑤	WIFI/GPRS	WIFI/GPRS interface	Connect WIFI/GPRS stick.
⑥	AC OUTPUT	AC output wiring hole	For AC output wiring.
⑦		Internal grounding wiring hole	For internal grounding wiring.
⑧	N	Neutral wire wiring hole	For neutral wire wiring.
⑨	COM1/COM2	Communication wiring hole	For RS485 wiring or DRM wiring.

DC Switch

The DC switch (as shown in the ② of Figure2-7) connects inverter with the PV string. Switch off the DC switch in the following situations for safety consideration.

- When installation and wiring, the DC switch must be set to OFF position.
- When checking and maintenance, the DC switch must be set to OFF position and wait for 30 minutes. Do not perform maintenance until there is no output voltage and current in the inverter (checked by detection equipment) and the DC bus voltage inside inverter is less than 10V.

2.2.4 Size

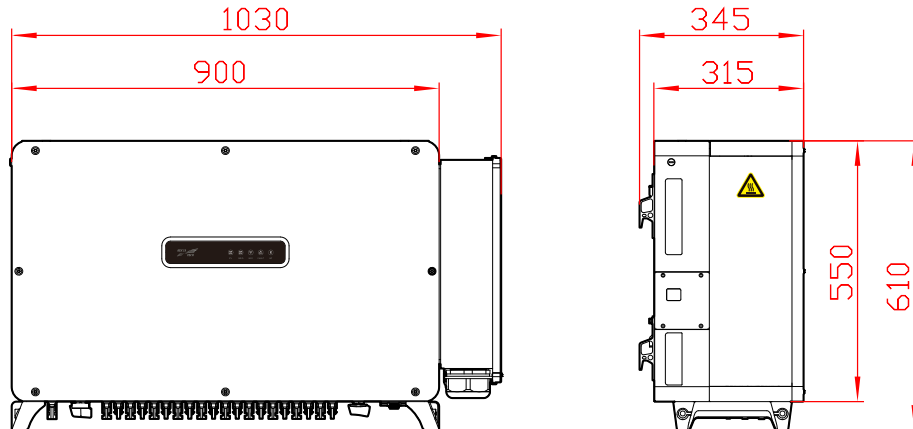

Figure2-8 Size (unit: mm)

2.3 Working Principle

PV strings are connected to inverter, and do the max. power point tracking for PV strings through the multi-groups of MPPT circuits inside inverter to achieve the max. power output of PV strings, and then convert the DC power into the three-phase AC power through the inverter circuit, as shown in Figure2-9 (take 9 groups of MPPT as an example).

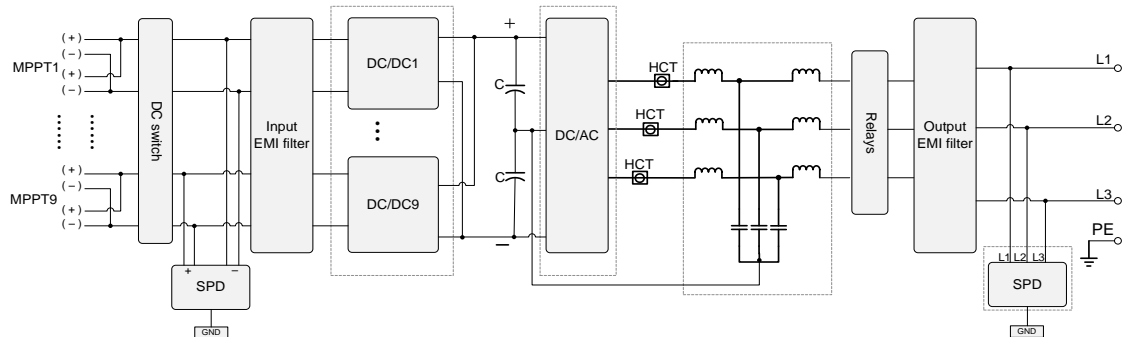

Figure2-9 Working principle diagram

2.4 Communication

The inverter has multiple communication methods, including RS485 communication, bluetooth communication, WIFI/GPRS communication (optional), and PLC communication (optional). User can easily obtain the running information of the inverter.

2.4.1 RS485 Communication

RS485 communication (as shown in Figure2-10) is mainly used for LAN monitoring, which can realize the background remote monitoring.

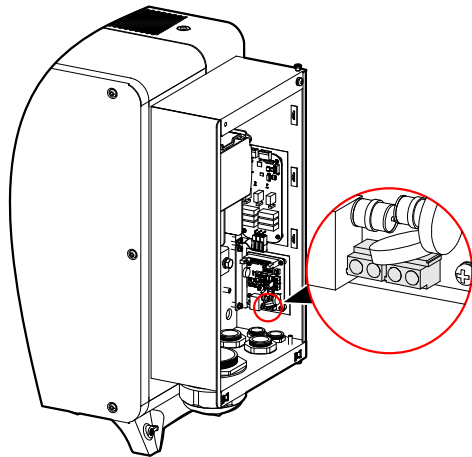

Figure2-10 The position of RS485 communication interface

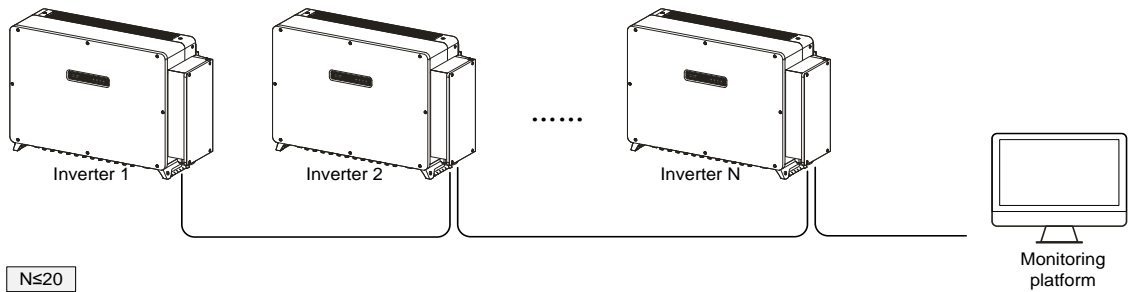

Figure2-11 RS485 communication (multiple inverters)



NOTE

When there is only one inverter adopts the RS485 communication, either of the two communication interfaces can be connected.

2.4.2 WiseSolar+APP

WiseSolar+APP can communicate with inverter through bluetooth to realize the short-distance maintenance. User can perform the information query, alarm query, event query, parameter setting, log download, etc. of inverter through APP.

If the GPRS/WIFI/4G stick made in Kehua is selected, WiseSolar+ APP can communicate with inverter through mobile data network or WIFI to realize the remote maintenance.

Download and install WiseSolar+APP:

- Method 1: search WiseSolar+ and download the WiseSolar+APP through the following application market, and the install the WiseSolar+ APP.
 - Application market (Android Chinese user) ;
 - Google Play (Excluding Chinese user) ;

- Huawei application market;
- APP store (iOS) .
- Method 2: scan the QR code below to download and install the WiseSolar+ APP according to prompting.



Figure2-12 QR code of WiseSolar+ APP

WIFI/GPRS interface is as shown in ④ of Figure2-7.

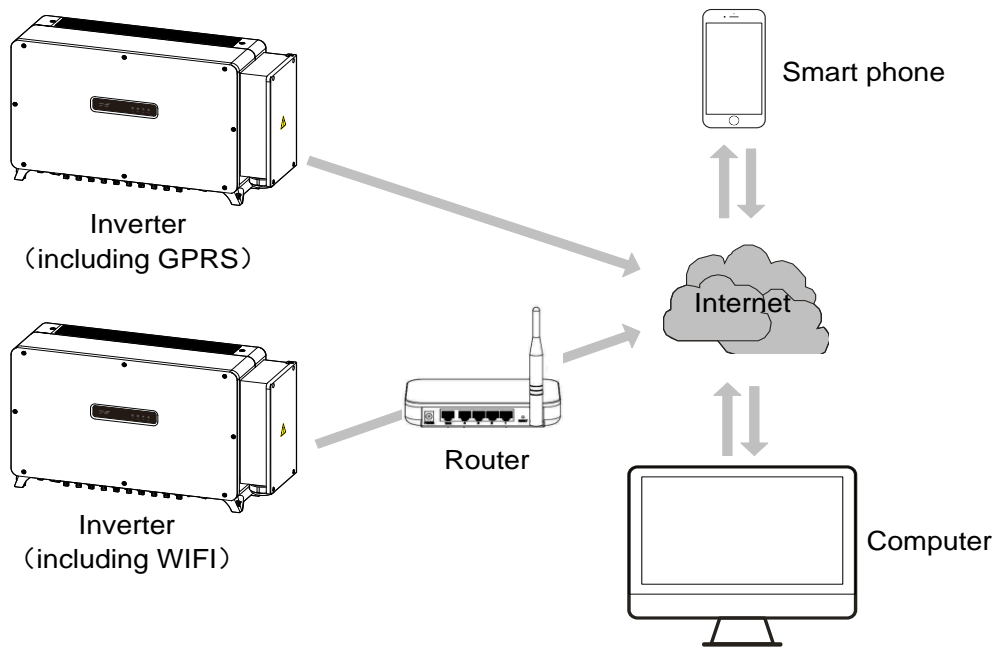

Figure2-13 WIFI/GPRS monitoring scheme

2.4.3 PLC Communication (Optional)

If the PLC communication is selected, the sub-array controller made in Kehua is required. The output of inverter passes through the isolation transformer and then connects with grid, as shown in Figure2-14.

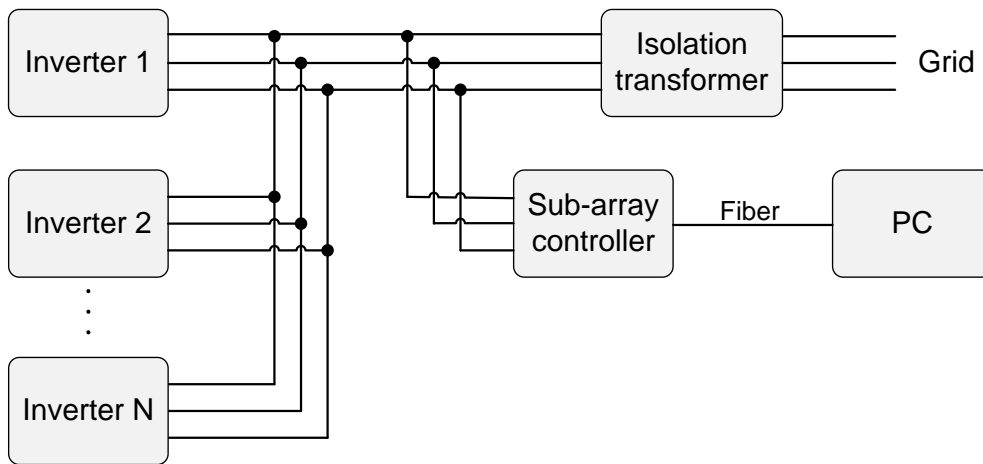

Figure2-14 PLC communication connection



NOTE

The setting of PLC communication address is the same as that of RS485, details please see **3.6.7 Communication Connection**.



If PLC communication is selected, the AC wire must be multi-core wire, not single-core wire.

The length of the AC cables between inverter and sub-array controller should be within 300mm and cannot exceed 400mm.

Sub-array controller

Smart sub-array controller uses an outdoor cabinet. Data collector, RS485 signal SPD, PID module and inductor, optical cable terminal box, PLC module, SPD, etc. can be installed in the cabinet to realize the communication and control of sub-array of PV power station. The network application scheme of the smart sub-array controller is as shown in Figure2-15.

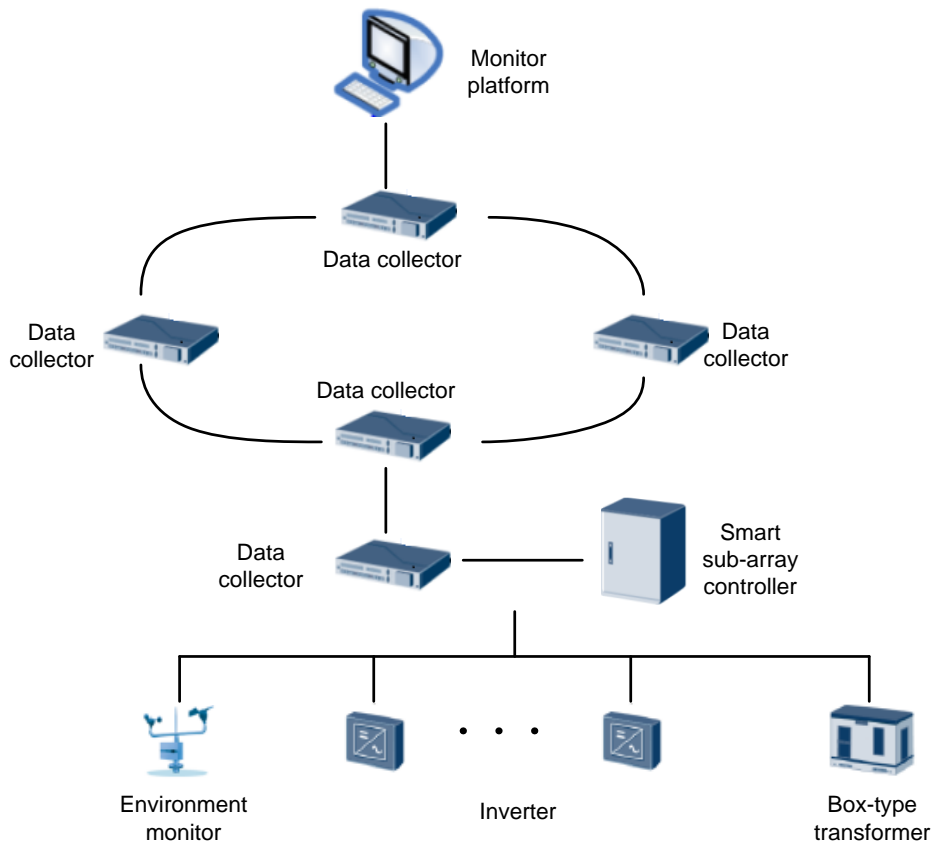

Figure2-15 Network application scheme of smart sub-array controller

2.5 PID Function (Optional)

If PID function is selected and enabled, the voltage of all PV strings to ground is greater than zero, that is to say, the voltage of all PV string to ground is positive voltage status.

CAUTION

Before enabling the PID protection or repair function, please pay attention to the polarity requirement for the voltage of different PV strings to ground. If any doubt, please contact the manufacturer of PV string or read the user manual of PV string.

When the type of PV string mismatches the voltage scheme of PID protection or repair function, the PID function will not reach the expected effect even cause harmful influence for PV string.

PID repair function

When the inverter doesn't work, the PID function module adds the reverse voltage for PV string to repair the PV string which has occurred the PID effect.

**NOTE**

After enabling the PID repair function, it only works at night.

After enabling the PID repair function, the default voltage of PV string to ground is 500Vdc.

When it need to enable the PID repair function, ensure the inverter is in the IT grid form.

3 Installation

This chapter mainly introduces the inverter's installation, including installation process, installation preparation, handling, unpacking and checking, installation procedures, electrical connection, check the installation, etc.

3.1 Installation Process

The installation process of the inverter is as shown in Figure3-1.

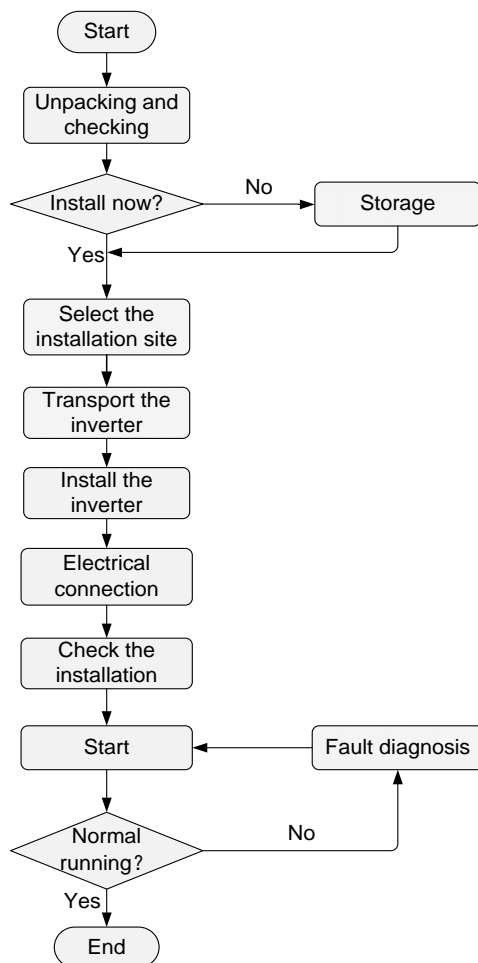

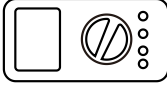

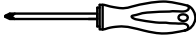
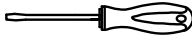





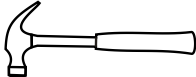
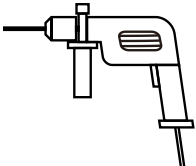
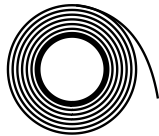
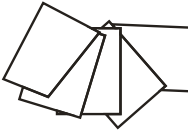

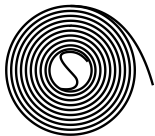
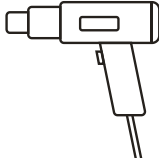

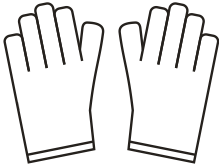
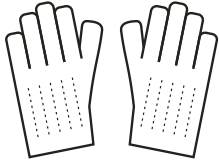
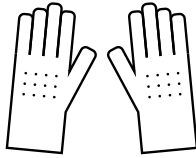



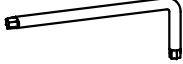

Figure3-1 Installation process

3.2 Installation Tools

The recommended installation tools include but not limited to the following tools, if necessary, you can also use other auxiliary tools according to the site conditions.

Tools			
 <p>Clamp meter (DC range $\geq 40A$, AC range $\geq 200A$)</p>	 <p>Multi-meter(DC voltage range) $\geq 1100V$)</p>	 <p>Label paper</p>	 <p>Phillips screwdriver</p>
 <p>Flat-headscrewdriver</p>	 <p>Socket wrench (M8, M10, M12)</p>	 <p>Adjustable wrench (M8, M10, M12)</p>	 <p>Torque wrench (M8, M10, M12)</p>
 <p>COAX crimping tool</p>	 <p>Diagonal pliers</p>	 <p>Wire stripper</p>	 <p>Claw hammer</p>
 <p>Hammer drill($\phi 14$)</p>	 <p>Insulation tape</p>	 <p>Cotton cloth</p>	 <p>Brush</p>
 <p>Heat shrink tubing</p>	 <p>Heat gun</p>	 <p>Electrician's knife</p>	 <p>Protective gloves</p>

Tools			
 <p>ESD gloves</p>	 <p>Insulated gloves</p>	 <p>Hydraulic pliers</p>	 <p>Cable tie</p>
 <p>Rubber hammer</p>	 <p>Wrench (T30)</p>		



The installation tools need to be insulated to avoid electric shock.

3.3 Selection of Installation Site

3.3.1 Installation Environment

The installation environment has a certain influence on the service life and reliability of the inverter. Therefore, please avoid using inverter in following environment.

- Do not install the inverter in the place where temperature and humidity beyond the technical specifications (temperature: -35°C~60°C, relative humidity: 0%~100%) .
- Do not install the inverter in the place where is closed and with poor ventilation.
- Do not install the inverter in the place where has flammable or explosive materials, dust, corrosive substances or salinity.

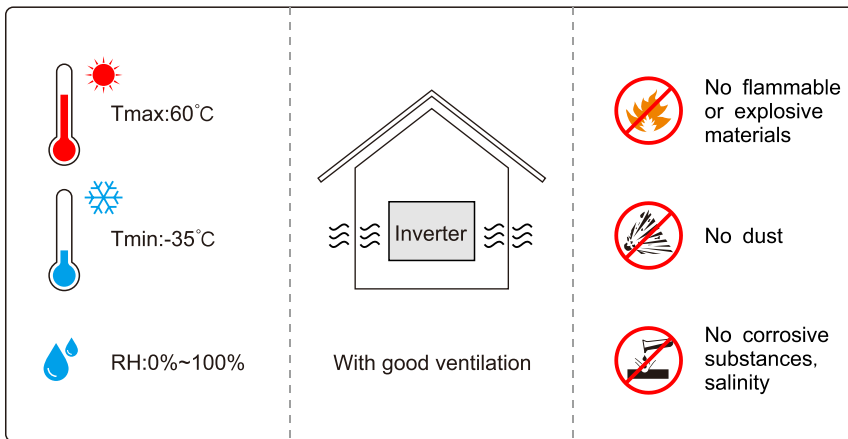

Figure3-2 Installation environment requirements

- As the inverter will make noise during working, avoid installing inverter near the residential area.

NOTE

Installation place will affect the safety operation, service life, performance guarantee of inverter. Therefore, avoid installing the inverter under direct sunlight, rain and snow, as shown in Figure3-3.

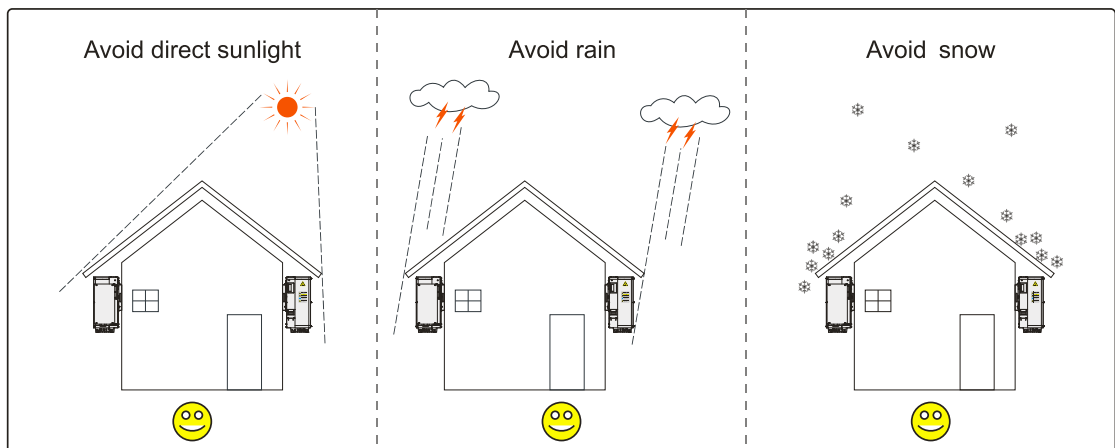

Figure3-3 Recommended installation place

3.3.2 Installation Clearance

- Keep a clearance of at least 800mm from the left side and right side of the inverter to other objects, keep at least 600mm from the top of the inverter to ceiling and at least 450mm from the bottom of the inverter to ground, which is good for heat dissipation or maintenance, as shown in Figure3-4.

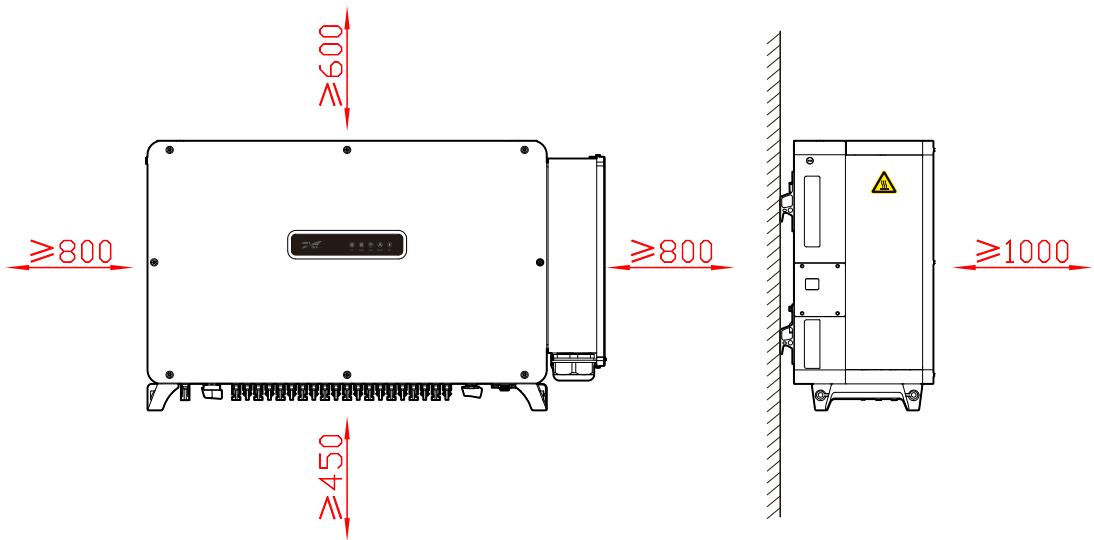

Figure3-4 Installation clearance (unit: mm)

NOTE

The installation height of the inverter should be convenient for viewing the status of the indicators, electrical connection, operation and maintenance, etc. The recommended clearance from the bottom of the inverter to ground is 600~800mm.

CAUTION

It is recommended that inverters aren't installed from top to down, which is to avoid influencing the heat dissipation of inverter.

- When multiple inverters are installed side by side, a certain clearance must be reserved between the inverters, as shown in Figure3-5.

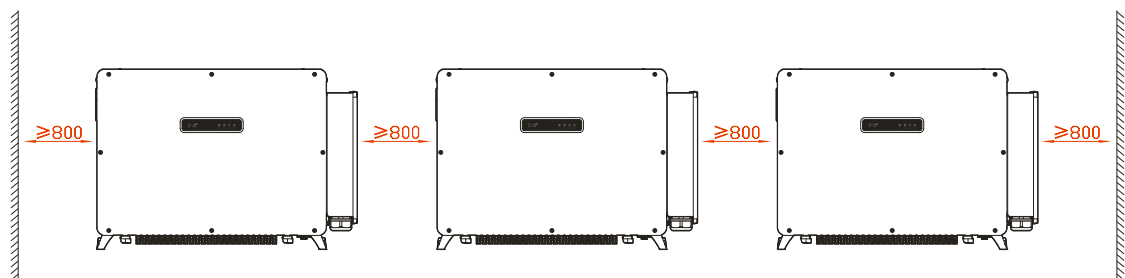

Figure3-5 Installation clearance requirements of multiple inverters (unit: mm)

- When the inverters are installed back to back, a certain clearance must be reserved between the inverters, as shown in Figure3-6.

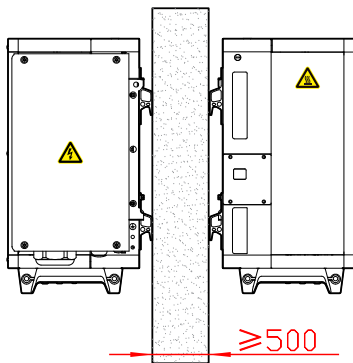

Figure3-6 Back-to-back installation clearance requirements (unit: mm)

3.3.3 Installation Carrier Requirements

The installation carrier of the inverter (such as wall, bracket) should meet the following requirements, as shown in Figure3-7.



The installation carrier can not be flammable material.



The max. bearing weight of installation carrier should be not less than 4 times of inverter weight.

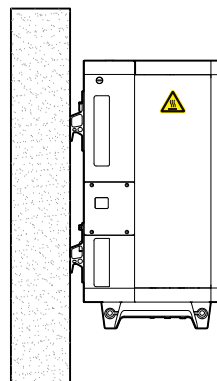

Figure3-7 Installation carrier requirements

3.3.4 Installation Method

It is recommended to install the inverter vertically or obliquely backwards (angle between inverter and wall is not more than 15°). Do not install inverter obliquely forwards or inverted.

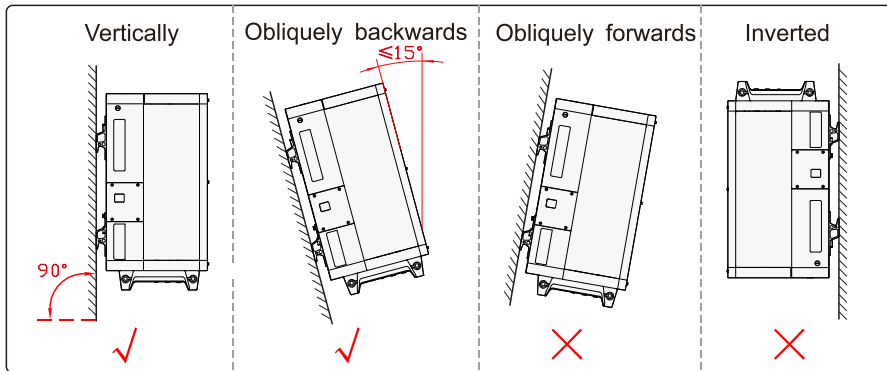

Figure3-8 Installation method

CAUTION

As the air flow of inverter is designed for top air outlet and down air inlet, it's recommended that the inverters isn't installed horizontally.

3.4 Transporting, Unpacking and Checking

3.4.1 Transporting

Before installation, the inverter needs to be transported to the selected installation site. When transporting, you can transport the inverter by the handle or the ring as required.

Handle transporting

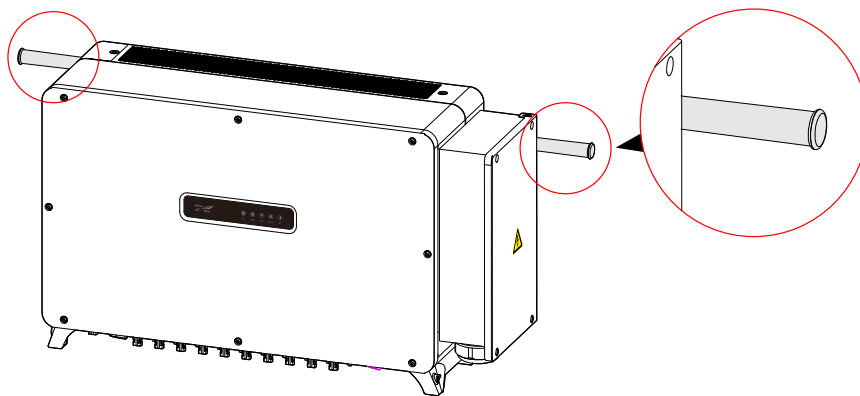

Figure3-9 Handle transporting

 **NOTE**

The handles are accessory. When adopting handle transporting, install the handles to inverter.

It's recommended that the inverter is transported by at least 4 people with protective equipment (such as smash-proof shoes, gloves) .

 **CAUTION**

During transporting,, move the inverter carefully to avoid impact or falling.

During transporting, pay attention to the gravity center of the inverter. Do not put down or lift up inverter suddenly.

Putting the inverter directly on a hard ground will damage the bottom terminals or case of inverter. It is necessary to lay protective materials (such as sponge pads or foam) under inverter.

Ring transporting

Figure3-10 Ring transporting

 **NOTE**

The ring are optional accessory. When adopting ring transporting, select rings and then install the them to inverter.

 **CAUTION**

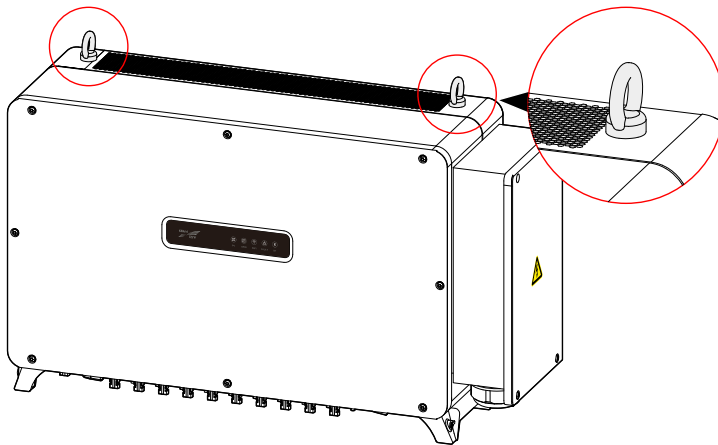
While hoisting, keep inverter balance and avoid collision with walls or other objects. In case of severe weather, such as heavy rain, heavy fog, strong wind, etc., stop the hoisting operation.

3.4.2 Unpacking and Checking

 **NOTE**

Determine the unpacking site in advance. Normally, the unpacking site should be as close to installation position as possible.

The inverter has been completely tested and strictly inspected before leaving the factory, but damage may still occur during transporting, so a detailed inspection is required after arrival.

- Inspect the inverter's appearance for shipping damage, if any shipping damage is found, report it to the carrier immediately.
- Check if the types of the accessories are complete and correct. If there is any discrepancy, take notes and contact the distributor immediately.

 **CAUTION**

After unpacking, if the inverter will be stored for a long time, it's recommended to pack the inverter with original plastic package.

3.5 Inverter Installation

The inverter can be installed on the wall or metal bracket via equipped installation holder.

3.5.1 Bracket Installation

- Step 1 Use the equipped four M4*10 combination bolts to fix the installation holder with the joint lever, as shown in Figure3-11.

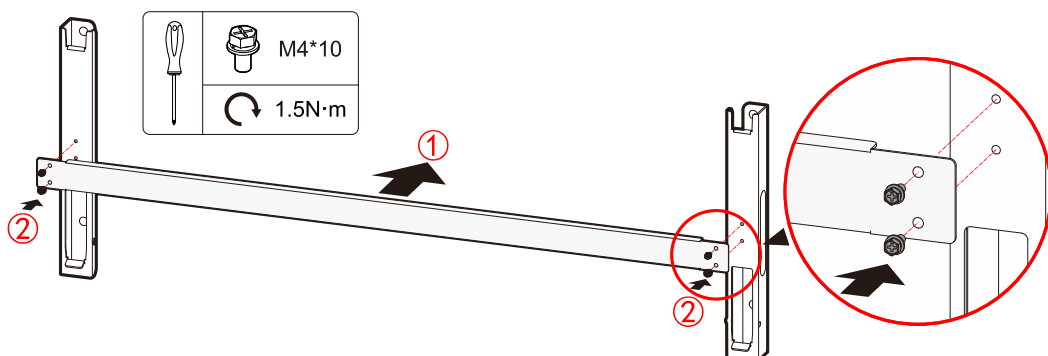

Figure3-11 Assemble installation holder

- Step 2 Place the assembled installation holder onto the installation site, use a horizontal ruler to adjust the angle, and mark the mounting hole position on the bracket, as shown in Figure3-12.



Keep the installation holder horizontal to ensure that the mounting holes are consistent and aligned.

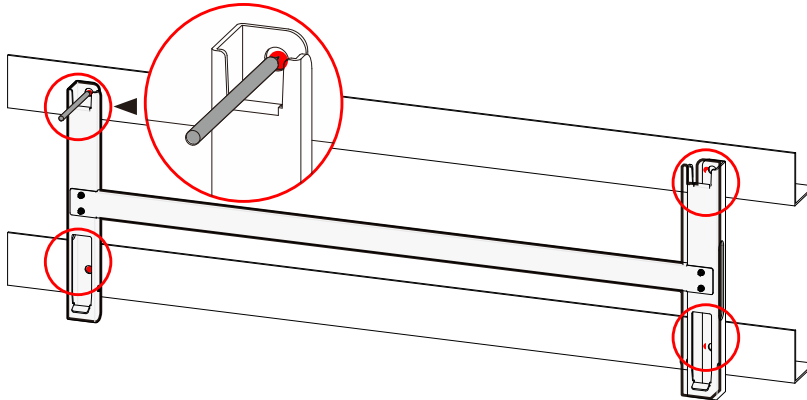

Figure3-12 Mark the mounting holes position



It also can mark the mounting holes position according to the mounting hole size of the installation holder (as shown in Figure3-13).

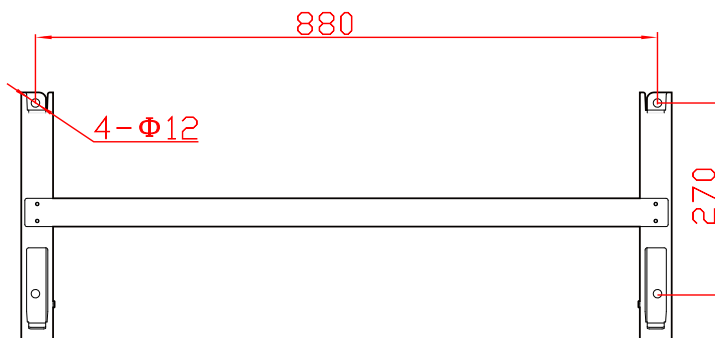

Figure3-13 Mounting hole size (unit: mm)

- Step 3 Use the electric drill to drill holes on the bracket according to the marked position. The drilling diameter is $\Phi 12$ mm, as shown in Figure3-14.

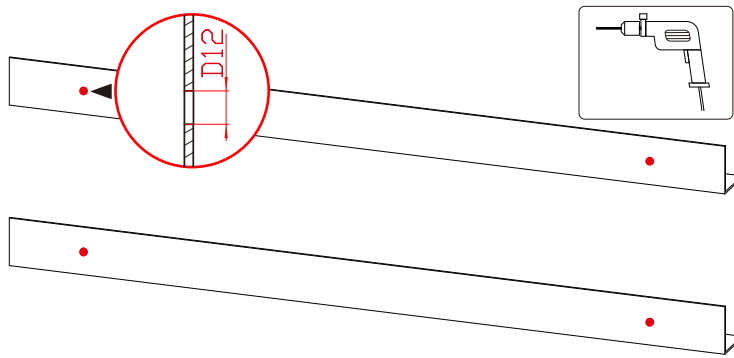

Figure3-14 Drill holes (unit: mm)

Step 4 Fix the installation holder to the bracket through M10*40 bolts, flat washers, spring washers and nuts, and then tighten the nuts clockwise through wrench, as shown in Figure3-15.

 **NOTE**

The equipped combination bolts are M10*40. If the length of the equipped combination bolts can not meet the necessary, please prepare the appropriate M10 bolts.

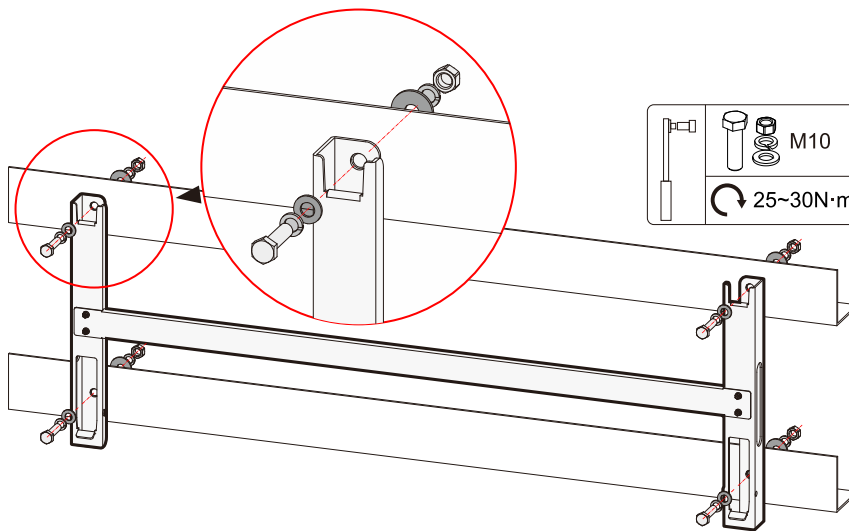

Figure3-15 Fix installation holder

Step 5 Lift the inverter to the installation holder, make sure that the mounting ears of the inverter and the groove of the installation holder fit well, and then slowly hang the inverter to the installation holder, as shown in Figure3-16.

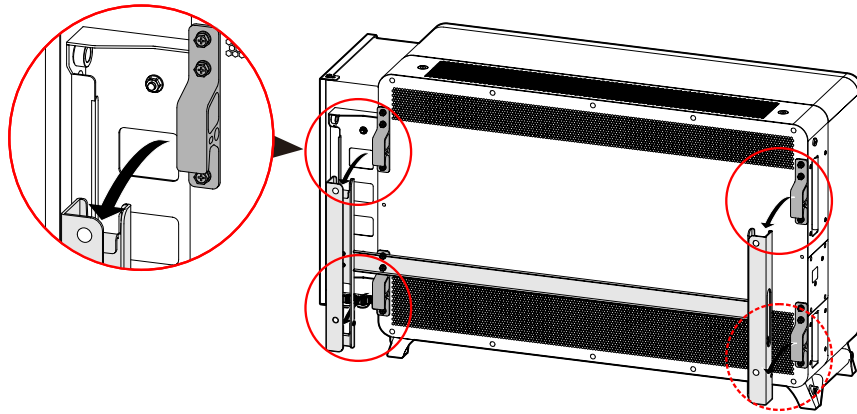

Figure3-16 Hang the inverter onto the installation holder



Do not loosen the inverter until it fixed firmly.

Step 6 Fix inverter to the installation holder through the equipped M5*50 screws, as shown in Figure3-17.

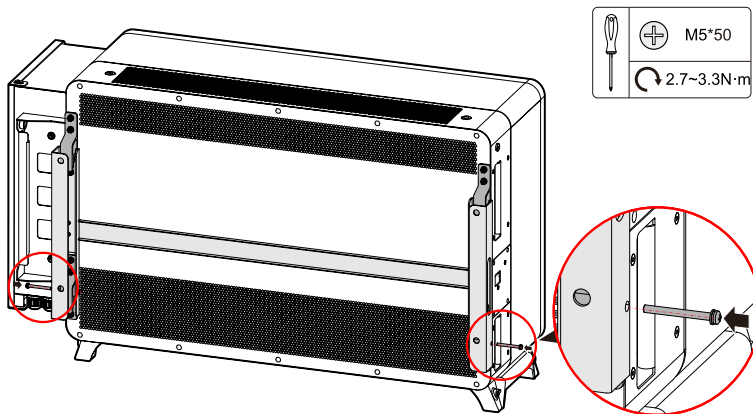

Figure3-17 Fix inverter

----End

3.5.2 Wall Mounting



NOTE

If adopt the wall mounting, it should prepare four stainless steel expansion bolts M10*80 in advance.

Step 1 Use the equipped four M4*10 combination bolts to fix the installation holder with the joint lever, as shown in Figure3-18.

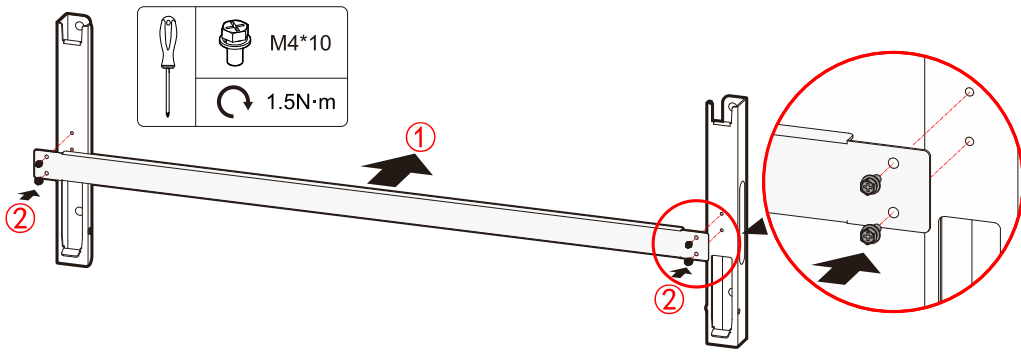

Figure3-18 Assemble installation holder

Step 2 Place the assembled installation holder onto the installation site, use a horizontal ruler to adjust the angle, and mark the mounting hole position on the bracket, as shown in Figure3-19.

⚠ CAUTION

Keep the installation holder horizontal to ensure that the mounting holes are consistent and aligned.

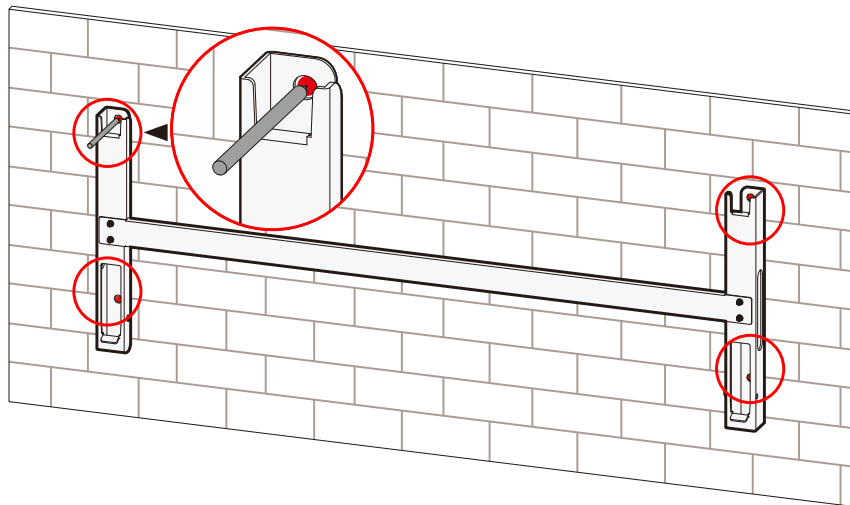

Figure3-19 Mark the mounting holes position

📖 NOTE

It also can mark the mounting holes position according to the mounting hole size of the installation holder (as shown in Figure3-20).

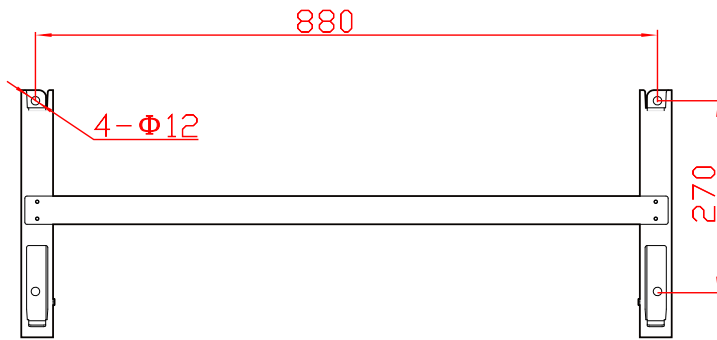

Figure3-20 Mounting hole size (unit: mm)

Step 3 Use the electric drill to drill holes on the wall according to the marked position. The drilling diameter is $\Phi 14.5\text{mm}$, and the drilling depth is 55~60mm.

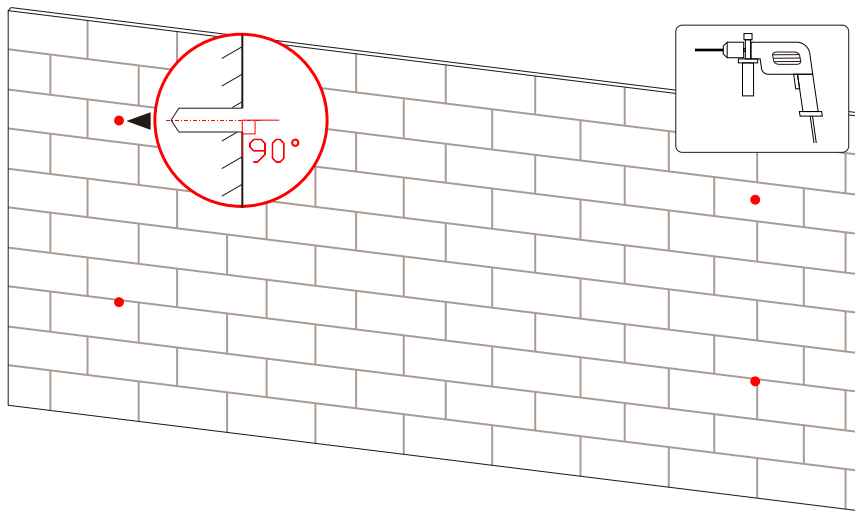

Figure3-21 Drilling holes

! CAUTION

After drilling, please clean the residues in the holes, and measure the depth of each hole to ensure that the depth of each hole is the same.

Step 4 Install expansion bolts. Install the four M10*80 expansion bolts into the installation holes, as shown in Figure3-22.

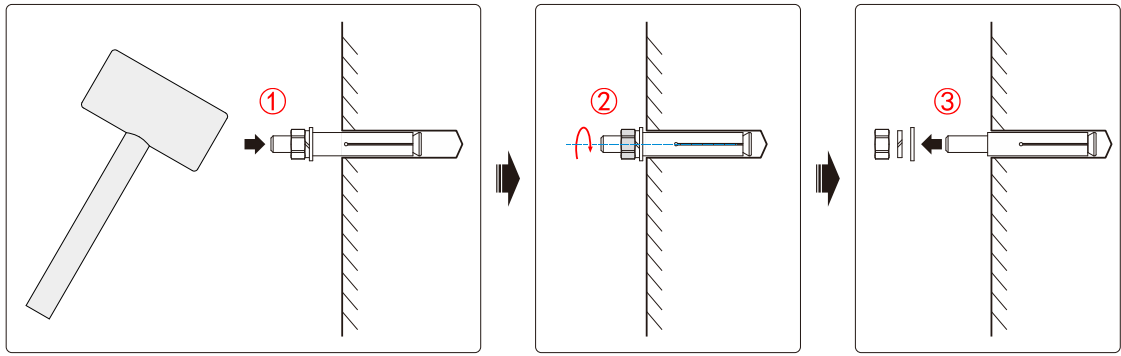

Figure3-22 Expansion bolt installation

Step 5 Install the installation holder. Fix the installation holder to the expansion bolts, put on flat washers, spring washers and nuts, and then tighten the nuts clockwise through wrench, as shown in Figure3-23.

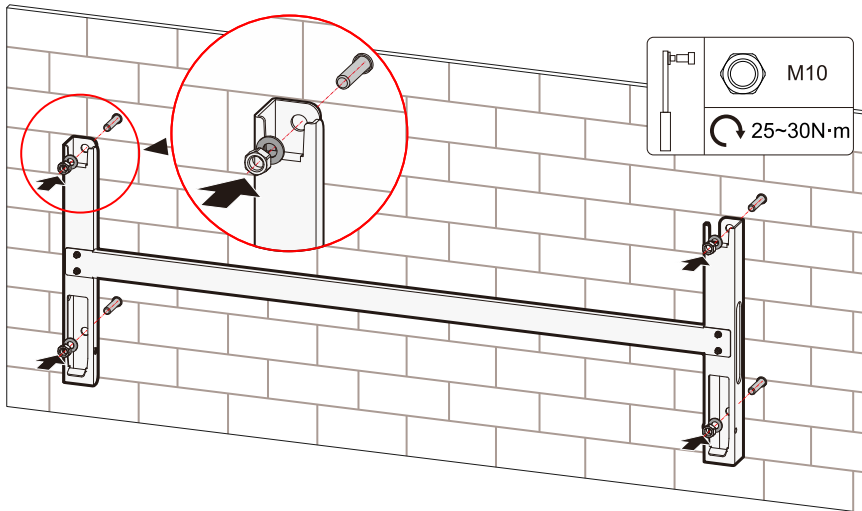

Figure3-23 Fix the installation holder

Step 6 Lift the inverter to the installation holder, make sure that the mounting ears of the inverter and the groove of the installation holder fit well, and then slowly hang the inverter to the installation holder, as shown in Figure3-24.

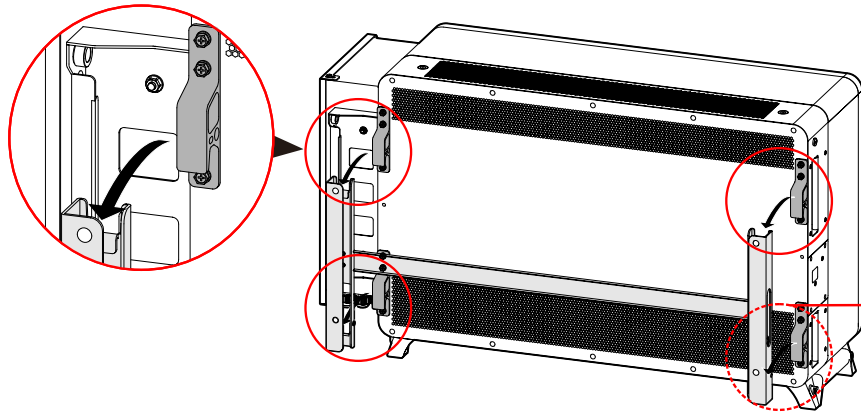

Figure3-24 Hang the inverter onto the installation holder



Do not loosen the inverter until it fixed firmly.

Step 7 Fix inverter to the installation holder through the equipped M5*50 screws, as shown as shown in Figure3-25.

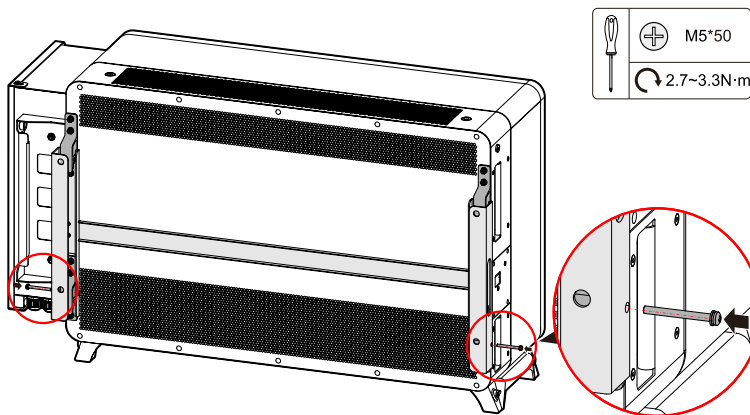

Figure3-25 Fix inverter

----End

3.6 Electrical Connection

3.6.1 Safety Announcements

During electrical connection, operators must wear protective equipment.

 **DANGER**

There may exist high voltage in the inverter.

PV string exposed to sunlight will generate dangerous voltage.

Do not switch on the DC switches and external AC switch until the electrical connection is completed.

Ensure that all wires are without electricity before performing electrical connection.

 **WARNING**

Any improper operation during wiring may cause equipment damage or human injury, so, wiring operation must be performed by professional technicians.

The wires used in the PV generation system must be firmly connected, intact, well insulated and with appropriate specifications.

 **CAUTION**

The wiring process must follow the local grid rule and the safety instructions of the PV string.

All electrical installations must comply with the electrical standards of the country or local region.

The inverter can not be connected to grid until getting the local power department permission.

3.6.2 Wire Requirements

The wiring terminals are located at the bottom of the inverter (as shown in Figure2-7). The recommended wires are as shown in Table3-1.

Table3-1 Wire requirements

Wire name	Wire type	Recommended cross-sectional area of wire
PV string input wire	PV wire with 1500V and above	4~6mm ²

Wire name		Wire type	Recommended cross-sectional area of wire
AC output wire	L1/L2/L3	Outdoor multi-core wire or single-core wire	Outdoor three-core wire: 70~240mm ² (Max. outer diameter<56mm) . Outdoor single--core wire: 70~240mm ² (Max. outer diameter<26mm) .
	N	Outdoor single-core wire	50~150mm ² (Max. outer diameter <25mm)
Internal grounding wire		Outdoor wire	The cross-sectional area of internal grounding wire is not less than S/2 (S is the cross-sectional area of AC output wire.) (Max. outer diameter <25mm) .
RS485 communication wire		Shielded twisted pair wire	2*0.3 mm ² (Maximum outer diameter<14mm)
External grounding wire		Outdoor wire	The cross-sectional area of external grounding wire is not less than S/2 (S is the cross-sectional area of AC output wire.) .

 **NOTE**

- The wires in above table are based on UL copper wire. If other wires are used, please replace them according to the standard. The wire materials selected by our company have passed the national standard certification or UL certification.
- If the recommended cross-sectional area of wire is not adopted, please confirm with our company.
- If using the aluminum wire, it should adopt copper-aluminum transition terminal.

3.6.3 External Grounding Connection



As the inverter is with no transformer, the positive and negative of the PV string cannot be grounded, otherwise the inverter will not operate normally.

Do not perform other electrical connection until the external grounding wire are connected firmly.

The grounding connection of the external grounding terminal cannot replace the connection of the internal grounding terminal. Make sure that both of them are grounded reliably, irregular operation is out of Kehua's guarantee range.

- Step 1 Strip the insulation layer of the grounding wire by crimping tool, and crimp it into the corresponding terminal, as shown in Figure3-26.

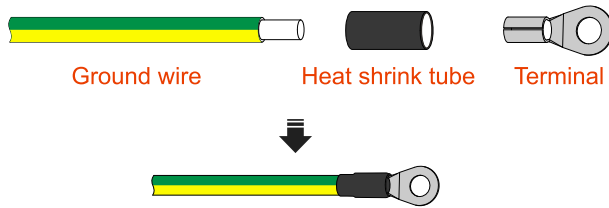

Figure3-26 Grounding wire crimping diagram

NOTE

It is recommended to use DT or OT terminal for the external grounding wire.

- Step 2 Connect the crimped grounding wire to the external grounding terminal at the bottom of the inverter, as shown in Figure3-27.

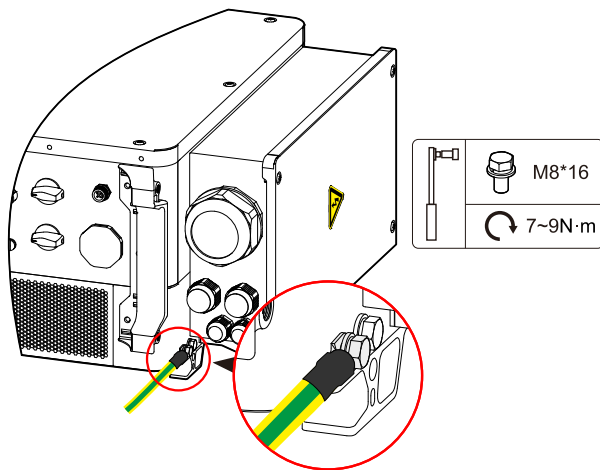

Figure3-27 External grounding connection

NOTE

There are two external grounding terminals reserved at the bottom of the inverter, either of them can be connected.

In order to improve the anti-corrosion performance of the external grounding terminal, it is recommended to paint anti-rust paint on the external grounding terminal after finishing the external grounding connection.

⚠ CAUTION

The grounding of inverter mustn't connect with the grounding of the lightning rod of the building where the inverter installs. It should separate them, or the lightning stroke will damage inverter, as shown in Figure3-28.

The grounding of the inverter should be directly connected to the grounding system, and the impedance should be less than 20mΩ.

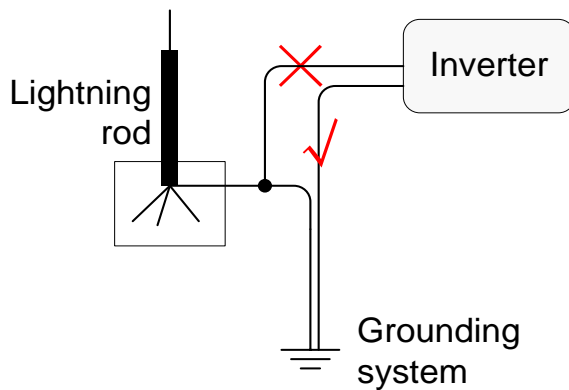

Figure3-28 The grounding of inverter

----End

3.6.4 AC Output Wiring

⚠ CAUTION

Before connecting to the grid, first make sure that the grid voltage and frequency meet the requirements of the inverter (see **A Technical Specifications**), otherwise, please contact the electricity company.

Each inverter should be equipped with an independent external three-pole switch (the recommended specification is as shown in Table3-2) in the AC side to ensure that the inverter can safely disconnect from the grid.

Table3-2 The recommended specification of the three-pole switch

Model	Rated voltage (V)	Rated current (A)
SPI75K-B, SPI80K-B, SPI90K-B, SPI100K-B, SPI110K-B, SPI125K-B	400	250
SPI136K-BHV, SPI150K-BHV	690	250

 **NOTE**

If multiple inverters share a switch, the switch selection depends on the total current.

 **CAUTION**

Load doesn't allow to be connected between the inverter and the switch.

MV transformer

The MV transformer matched with string inverter must meet the following requirements:

- The selected transformer can be a distribution transformer, which can meet the typical periodic load PV system (that is, there is load during the day and no load at night). Dry-type transformer or oil-immersed transformer is optional, and shielded winding is optional.
- The line voltage on the low-voltage side of the transformer must match the line voltage output by the AC side of the inverter. When connected to the IT grid, the low-voltage side windings of the boost transformer, AC wires, and secondary equipment (including relay protector, detection meter and related auxiliary equipment) must have a ground withstand voltage not lower than the system voltage of 1100V.
- The line voltage output from the high-voltage side of the transformer should be consistent with the output of grid voltage at the installation site. It is recommended to use a transformer with a tap changer on the high-voltage side.
- If the ambient temperature is 45°C, the transformer can operate at 110% load for a long time. The transformer has the overload protection and short-circuit protection.
- The transformer that the short-circuit impedance is 6% (the allowable error is $\pm 10\%$) is preferred. Besides, the voltage drop of system wires should be not more than 3%.
- The allowable DC component of transformer is the 1% of the fundamental current at rated power.

- The apparent power of inverter can not exceed the transformer power. The max. AC current of all paralleled inverters must be considered.
- As a part of the PV grid-connected power generation system, the carrying capacity of the transformer must be considered when the system fails(including system short-circuit, grounding fault, voltage drop, etc.) .
- When selecting the transformer type or installing the transformer, the installation position environment (such as ambient temperature, ambient humidity, altitude, air quality, etc.) must be considered.

Terminal requirements

- When the AC output uses copper wire, it is recommended to use DT/OT terminals (as shown in Figure3-29). The terminal size requirements are: $13\text{mm} \leq A \leq 15.5\text{mm}$, $B \leq 46\text{mm}$, $C \leq 22\text{mm}$.

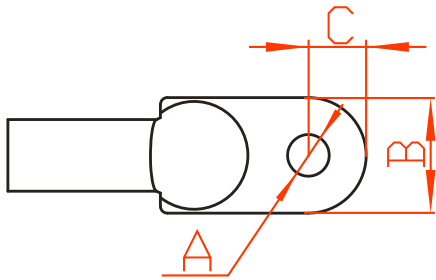

Figure3-29 Terminal size requirements

- When the AC output uses aluminum wire, copper-aluminum transition terminal is required to avoid direct contact between the copper bar and the aluminum wire.

Wiring steps



Before wiring, add marks for AC output wires to avoid wrong connection.

- Step 1 Dismantle the right cover of the wiring box by wrench, as shown in Figure3-30.

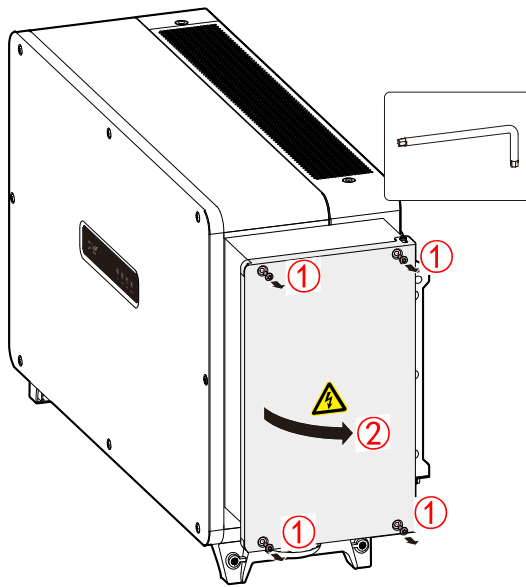

Figure3-30 Dismantle the right cover of the wiring box

NOTE

A limiting lever is designed inside the wiring box. After the wiring cover is opened, fix the limiting lever (as shown in Figure3-31) to facilitate the wiring operation.

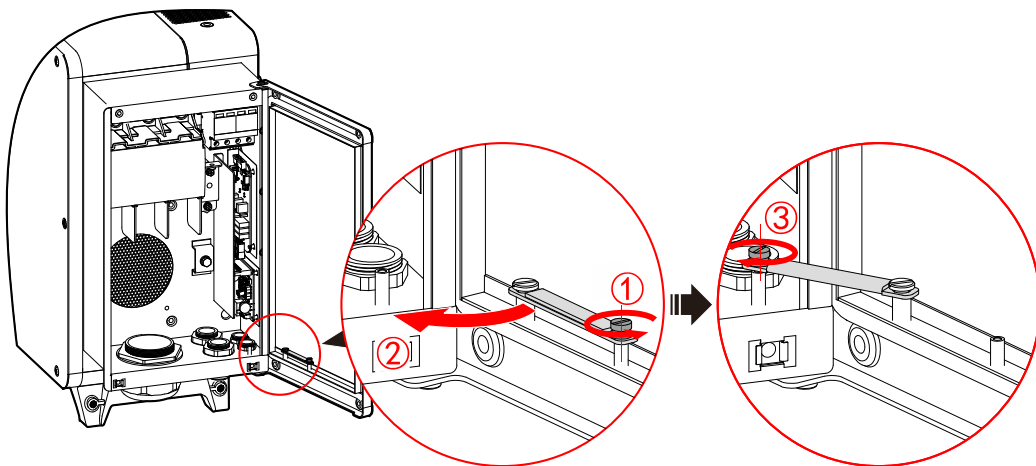

Figure3-31 Limiting lever operation

Step 2 Loosen the nylon cable gland in the "AC OUTPUT", draw the L1, L2, L3, N wires through the nylon cable gland, and strip the L1, L2, L3 and N wires respectively through wire stripper, and crimp them to the terminal, and then connect the L1, L2, L3 and N wires to the AC output terminal, as shown in Figure3-32.

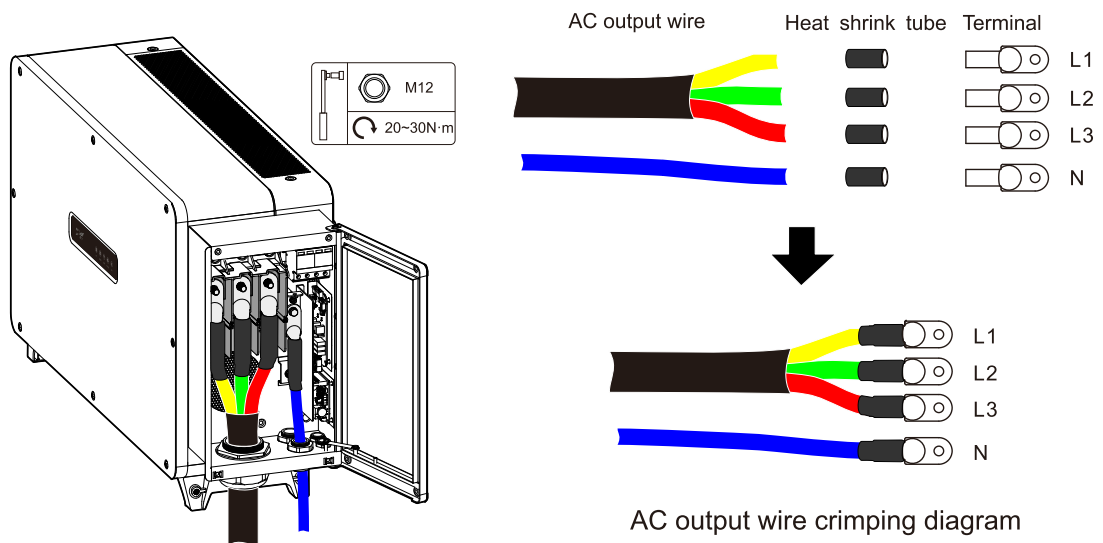

Figure3-32 Connect the AC output wire

NOTE

The torque of the nylon cable gland in the "AC OUTPUT" is about 15~19N·m.
 The insulation baffles among terminals can not be dismantled.

CAUTION

In order to avoid excessive stress on the wire, draw the AC output wire vertically into the inverter, and the external straight length of the AC output wire should be not less than 200mm, as shown in Figure3-33.

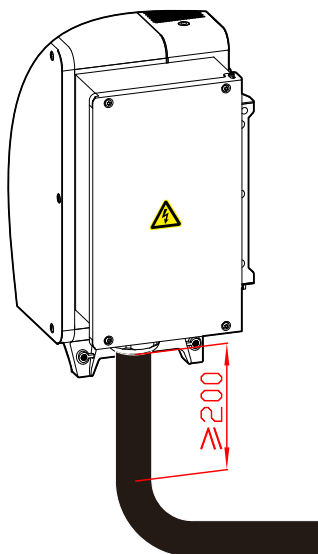

Figure3-33 AC output wiring requirements (unit: mm)

 **NOTE**

- When leaving the factory, the wire outlet is sealed. Before wiring, puncture it by tool.
- Please connect the AC output wire based on the local country requirements.

Step 3 Tighten the nylon cable gland in the "AC OUTPUT" clockwise, block the AC output wiring hole by fireproofing mud.

----End

3.6.5 Internal Grounding Connection

Loosen the nylon cable gland in the "⊕", draw the grounding wire through the nylon cable gland, and strip the grounding wire through wire stripper, and crimp it to the terminal, and then connect the grounding wire to the inner grounding terminal, as shown in Figure3-34.

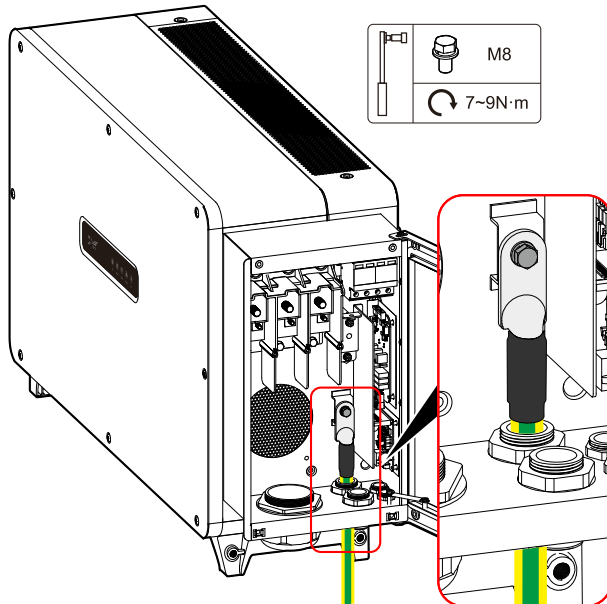

Figure3-34 Connect the internal grounding wire

 **NOTE**

The torque of the nylon cable gland in the "⊕" is about 10~13N·m.

3.6.6 PV String Input Wiring

 DANGER

PV string exposed to sunlight will generate dangerous voltage.

 WARNING

If the PV string input wires are reverse connected and the "DC SWITCH" has be set to ON position, do not immediately operate the "DC SWITCH" and the positive and negative connectors, or, it may cause inverter damage, which is out of the Kehua guarantee range. It needs to wait until night when the solar irradiance decreases and the PV string current drops below 0.5A, then set the corresponding "DC SWITCH" to OFF position, connect the positive and negative connectors correctly.

 CAUTION

Before connecting the PV strings to the inverter, ensure that the PV string is well insulated from ground.

When installing, use the DC terminals and PV connectors in the accessories, or, the inverter will be damaged. If they are lost or damaged by accident, please purchase the same type of PV connector. Inverter damage caused by the using incompatible PV connectors is out of the Kehua guarantee range.

Switch off the DC switches before connecting the PV strings.

Ensure that the positive and negative poles of the PV string and the inverter are correctly connected.

Ensure that the DC input voltage is less than 1100Vdc, and the max. short-circuit current of the PV string is within the allowable range of the inverter.

It is strictly prohibited to connect the positive and negative poles of PV strings to ground, or, it will cause damage to the inverter.

After finishing installation, check whether the connectors in the PV side and the connectors in the inverter side are connected well. PV connectors damage or inverter damage caused by poor connection is out of Kehua guarantee range.

Use the DC terminals and PV connectors in the accessories for DC input wiring. There are two types of PV connectors: positive connectors and negative connectors, which respectively use positive metal terminals and negative metal terminals. The specific steps are as follows.

Connect PV connectors



Before wiring, add marks for PV string input wire to avoid wrong connection.

- Step 1 Strip the insulation layer of the positive and negative cables for 7mm by wire stripper to, as shown in Figure3-35.



Figure3-35 Strip the PV string input wires (unit: mm)

NOTE

It is recommended to use red wires for positive and black wires for negative to avoid wrong connection. If other color wires are used, please confirm the corresponding relationship when crimping each wire to the connector.

- Step 2 Loosen the lock nuts of the positive and negative connectors, draw the positive and negative wires through the corresponding lock nuts, and crimp the positive wire and negative wire to the positive and negative metal terminals respectively, and then check whether the positive and negative wires are crimped firmly, as shown in Figure3-36.

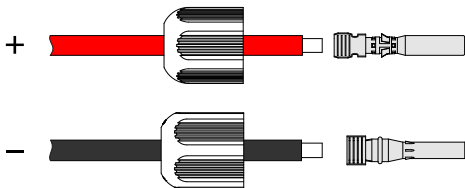

Figure3-36 Crimp the metal terminals

- Step 3 Insert the crimped positive and negative wires into the corresponding insulated shells until you hear a clicking sound, it means the connection is good.

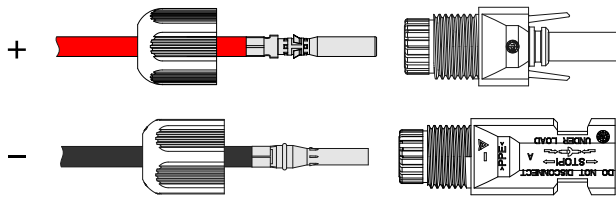

Figure3-37 Fix the metal terminals

Step 4 Tighten the locking nuts of the positive and negative connectors to corresponding insulating shells, as shown in Figure3-38.

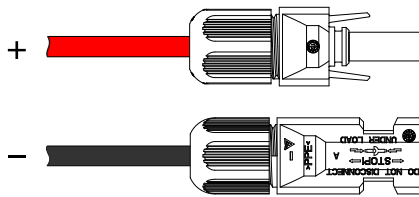

Figure3-38 Tighten the lock nut

----End

Type-Y PV connector wiring



When wiring by type-Y PV connector, the type of all connectors must match that of the inverter. If using the connectors with different manufacturers or different types together, the contact resistance of the connector may exceed the allowable value, and connector will continue to heat and oxidize, which is easy to have an fault.

When wiring by type-Y PV connector, the total current of PV string connected to each MPPT should be less than the max. input current of inverter (30A or 40A).

Wiring requirements:

1. Only an type-Y PV connector can be connected to each MPPT.
2. The PV+ in the inverter side must be connected to the PV+ in the PV string side, and the PV- in the inverter side must be connected to the PV- in the PV string side. Do not connect them reversely.

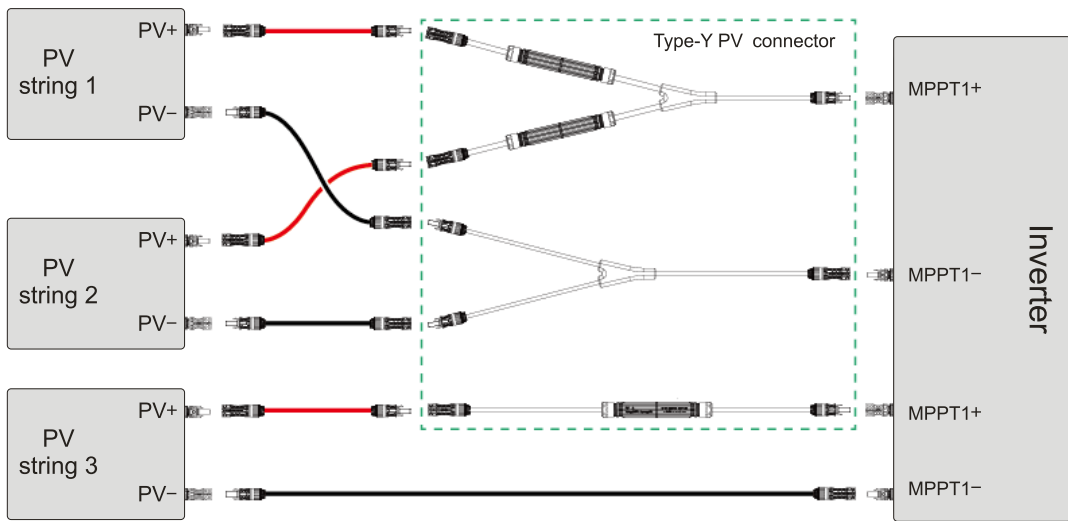

Figure3-39 Wiring diagram (connection in the inverter side)

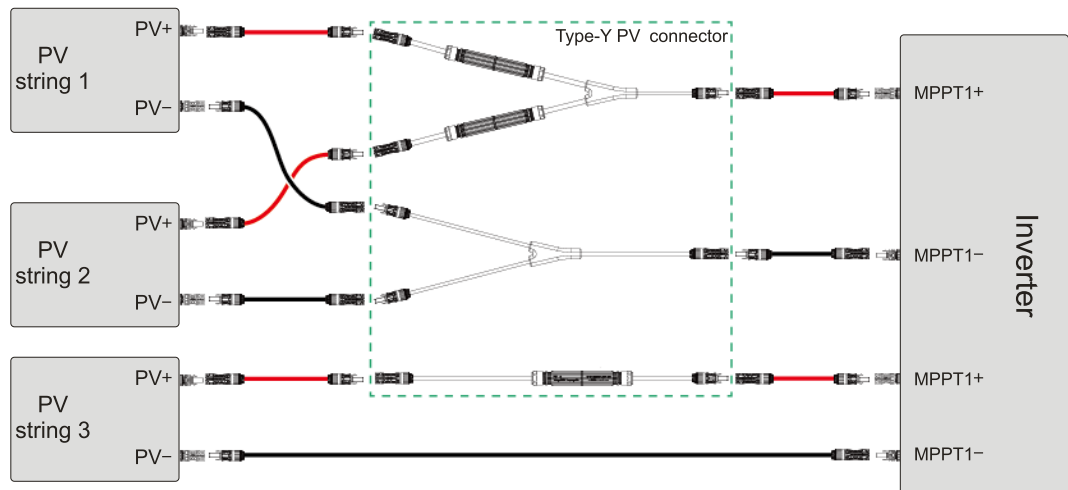

Figure3-40 Wiring diagram (connection in the PV string side)

Install PV connectors

Step 1 Ensure that all DC switches on the inverter (as shown in the ② of Figure2-7) are set OFF position.

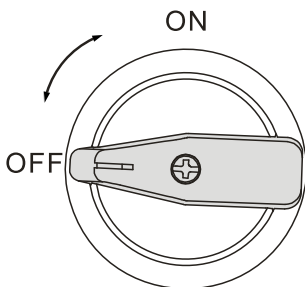

Figure3-41 DC switch in the OFF status

- Step 2 Check whether the polarity of the PV string is correct, and ensure that the open-circuit voltage in any case does not exceed the max. input voltage of the inverter 1100V.

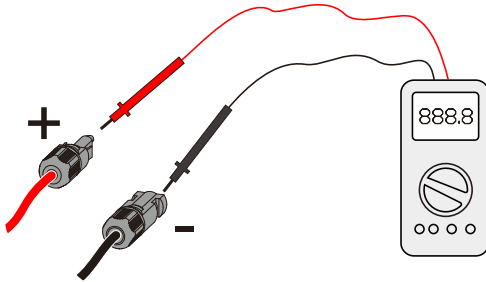

Figure3-42 Measuring the open-circuit voltage

- Step 3 Insert the positive and negative connectors into the MPPT "+" and "-" terminals at the bottom of the inverter respectively (as shown in Figure3-43). When you hear a click, it means the connection is good.

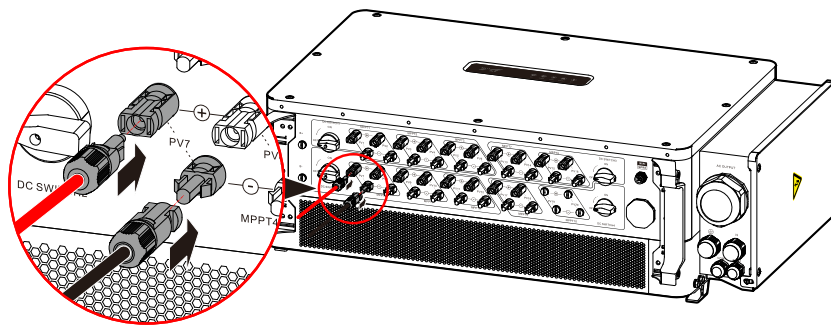

Figure3-43 Connect PV connectors

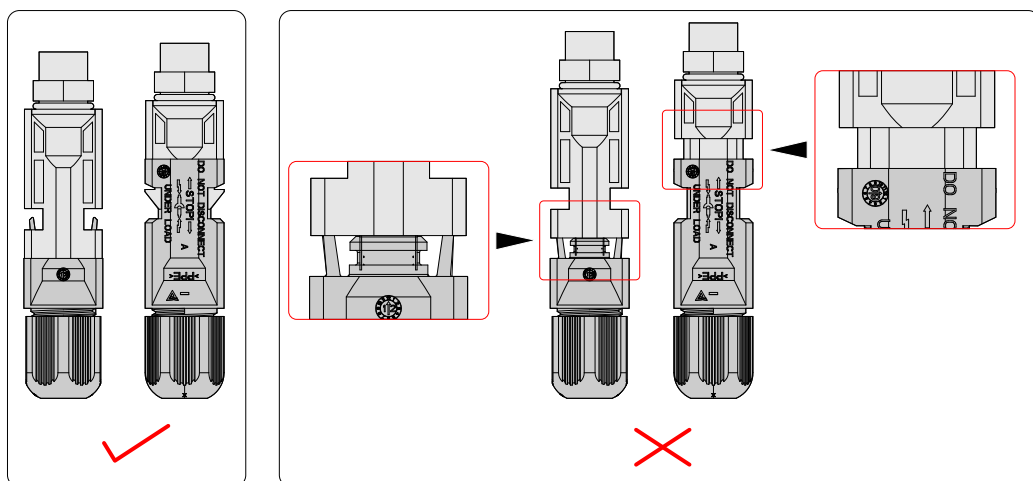

Figure3-44 PV connector installation method

⚠ CAUTION

If any PV connector on the inverter is not connected to PV string, block it with original plug.

----End

3.6.7 Communication Connection

- Step 1 Plug RS485 communication wire into the RS485 port on the communication board, as shown in Figure3-45. Connect the other end of the RS485 communication wire to the monitoring platform.

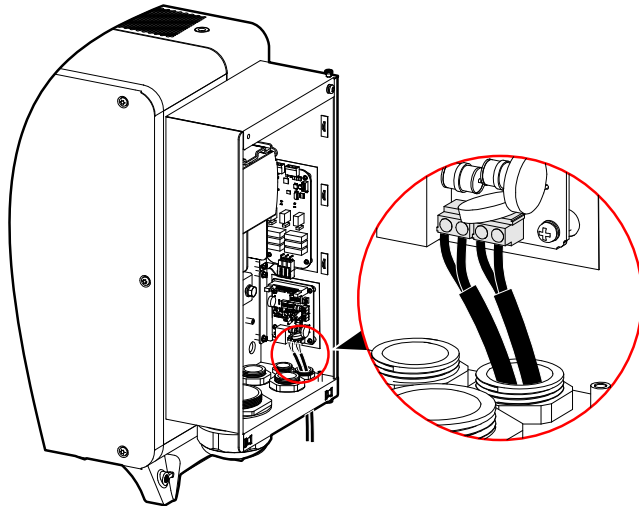

Figure3-45 RS485 connection

⚠ CAUTION

When wiring, do not press the insulation layer of the communication wire, otherwise it may cause poor contact.

The RS485 communication wire must be routed separately from the input and output wires to avoid communication interference.

📖 NOTE

The baud rate of the inverter needs to be set through Kehua monitoring software WiseEnergy (for details, please refer to the **About-User Manual** in WiseEnergy). The default baud rate is 9600. The communication address of the inverter is set in binary mode through the dial switch SW1 (as shown in SW1 position) on the communication board, for example: when the dial switch SW1 is set to "000001 (from left to right, ON is 1, OFF is 0)", which means the communication address of the inverter is 1, and so on. If any doubt, please contact the manufacturer.

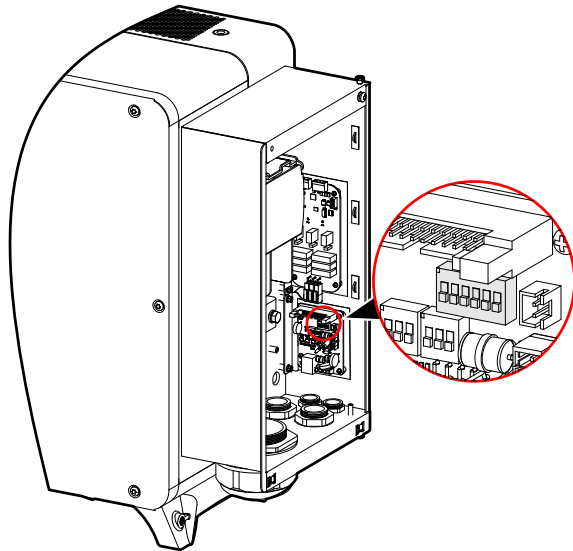

Figure3-46 SW1 position

 **NOTE**

When multiple inverters communicates, the dial switch SW2 on the communication board of first and last inverters on the communication link must be set to the ON position.

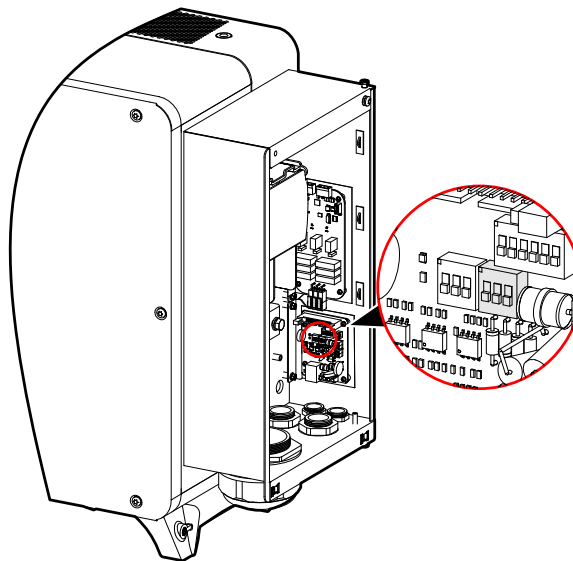

Figure3-47 SW2 position

 **CAUTION**

The communication address of the inverter must not conflict.

Step 2 After wiring, tighten the nylon cable gland in the "COM1/COM2", block the communication wiring holes by fireproofing mud, and install the right cover of the wiring box.

----End

3.7 Check the Installation

After finishing the installation, check the following items:

- Check if the PV string input wire, AC output wire and communication wire are connected rightly.
- Check if the inverter is installed firmly.
- Check if all the screws on the surface of the inverter are tightened.

4 Startup and Shutdown

This chapter mainly introduces how to start and shut down the inverter.

4.1 Check Before Startup

Before starting inverter at the first time, please check the following items.

- Ensure that the inverter is properly installed and fastened.
- Ensure that the DC switches and external AC switches are all in the OFF position.
- Ensure that the polarity of PV strings are correct.
- Ensure that all wires are fastened and the insulation layer of wires are good.
- Ensure the gap between the nylon cable gland and wires and the unconnected connectors are sealed well.
- Ensure that the grid voltage meets the AC voltage requirement of the inverter.
- Ensure that the cross-sectional area of the input wire meets the max. load current of inverter.
- Ensure the wiring holes of inverter are blocked by fireproofing mud.
- Ensure that the distance among AC terminals meets the requirements of safety standard.
- Ensure that the input voltage of each PV string is same.

4.2 Start Inverter



Damaged device or device fault may cause electric shock or fire!

- Before operation, please check if the inverter is damaged or has other danger.
 - Check if the external device or circuit connection is safe.
-

After ensure the inverter is normal, start inverter according to following steps.

- Step 1 Switch on the DC switches on the inverter and the project site. When the PV string provides enough startup voltage, PV string indicator will be on.
- Step 2 Switch on the AC switch between inverter and grid, a moment later, the fault indicator will be off.
- Step 3 When the DC and AC power are all normal, the inverter will prepare to start.
- Step 4 A moment later, the inverter will generate power normally. The grid indicator will be on.

----End

4.3 Shut Down Inverter



When the inverter works normally, do not switch off the DC switches and AC switch with load to avoid switch damage for arc. At worst, the inverter may be damaged.

- Step 1 Switch off the external AC switch between the inverter and grid.
- Step 2 Switch off the DC switches on the inverter and project site, a moment later, the PV string indicator will be off.

----End

5 Maintenance and Troubleshooting

This chapter mainly introduces the maintenance and troubleshooting.

5.1 Maintenance



NOTE

If any maintenance service is needed, please contact the after-sale service centre of Kehua Company, otherwise, Kehua Company will not undertake the responsibility and guarantee for the loss caused by self-operation.



CAUTION

For human safety, before checking and maintenance, switch off the external AC switch, and switch off the DC switches on the inverter and wait for 30 minutes. Do not perform maintenance until there is no output voltage and current in the inverter (checked by detection equipment) and the DC bus voltage inside inverter is less than 10V.

5.1.1 Maintenance Details and Period

To ensure the inverter works in best condition, we suggest maintaining the inverter regularly.

Table5-1 Check list

Item	Check method	Maintenance period
Cleanness of system	Check if there is dust or sundries on air outlet holes or heat sink. Clean the air outlet holes and heat sink if necessary.	Every half or one year (it is decided by the dust of the environment)
Electrical connection	Check if the wiring is loose or dropping. Check if there is damage on the wires, especially the surface touching with metal, if damaged, please	Every half or one year

Item	Check method	Maintenance period
	maintain it in time.	
Wire Inlet hole	Check if the wire inlet holes are sealed up completely, if not, seal them with fireproof mud.	Every year
Fan	Check if there is abnormal noise on fan when running. Check if the blade of fan has crack. If necessary, replace the fan (refer to 5.1.2 Maintenance Guide)	Every year (if the operating environment with lots of sand and wind, short the maintenance period)
LED indicator	If the surface of the LED indicator is too dirty to read, you can clean it with a damp cloth.	In necessary



Do not clean the inverter with any solvent, abrasive material or corrosive material.



During running, please don't touch the surface to avoid scald. Shut down inverter and wait until it cooling down, then do the maintenance.



When the power generation value displayed on the monitoring platform is inconsistent with the external measurement device, user can correct the power generation value of the monitoring platform according to the Kehua communication protocol.

The correction formula is: Total power generation compensation value = Measurement value of measurement instrument - Monitoring platform displayed total power generation value.

5.1.2 Maintenance Guide

Clean air inlet & outlet holes

During operating, the inverter will generate large heat, so, the inverter designs the cooling way of forced wind-cooling. To ensure good ventilation, it is necessary to check the air inlet & outlet holes and keep them unblocked. If necessary, use a soft brush to clean the air inlet & outlet holes.

Fan maintenance



Before maintenance, shut down the inverter and disconnect all power input.

Wait for 30min at least, after the inner capacitor discharge completely and check that there is no voltage and current in the inverter by the detection equipment, the maintenance can be done.

The maintenance and replacement for fan only can be done by professionals.

The inner fans are used for cooling and heat dissipation while operating. If the fans cannot work normally, it will influence the inverter efficiency or cause derating running. So, keep the fan clean and replace the damaged fan in time. The fan's cleanness and replacement procedure as follows.

- Step 1 Shut down the inverter (see **4.3 Shut Down Inverter**).
- Step 2 Loosen the screws of fan cover, as shown in Figure5-1.

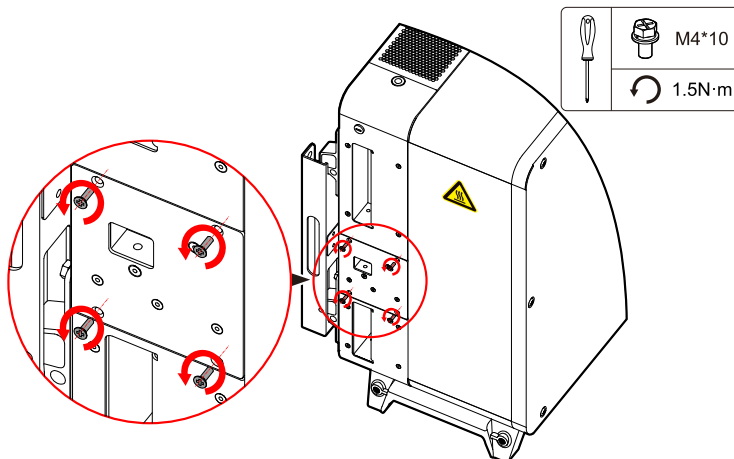

Figure5-1 Loosen the screws of fan cover

- Step 3 Pull out the fan module gently and loosen the connector of fan.

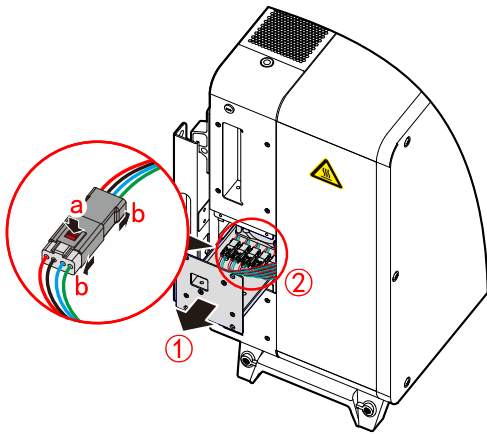

Figure5-2 Loosen the wiring of fan module

Step 4 Pull out the fan module, clean the fan by brush or cleaner or replace damaged fan.

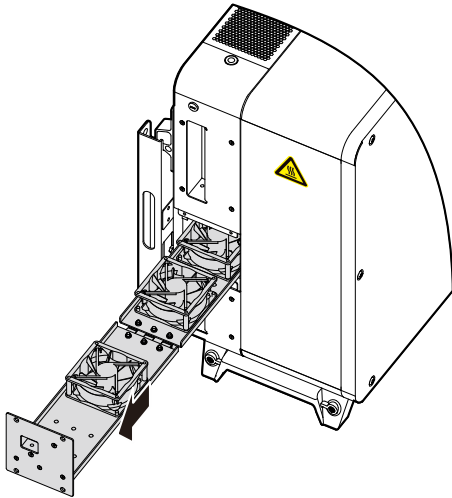

Figure5-3 Pull out fan module

Step 5 Install the fan module in reversed order and lock the screws, restart the inverter.

----End

5.2 Troubleshooting

The inverter is designed on the basis of the grid-tied operation standards and meets the requirements of safety and EMC. Before provided to client, the inverter has been experienced for several rigorous tests to ensure reliable and optimizing operation.

If some faults occur, the touch screen will show the corresponding alarm information. Under the circumstances, the inverter may stop power generation. The fault situation is as shown in Table5-2.

Table5-2 Troubleshooting list

No.	Fault information	Solution
1	Grid voltage abnormal	Check whether the safety regulations of the inverter meet the requirements of the local grid connection and check the voltage of the local power grid. If the above is normal, please contact your local agency or service center.
2	Grid frequency abnormal	Check whether the safety regulations of the inverter meet the requirements of the local grid connection and check the frequency of the local power grid. If the above is normal, please contact your local agency or service center.
3	Output over-current	If the fault persists, please contact your local agency or service center.
4	Output current DC component abnormal	If the fault persists, please contact your local agency or service center.
5	Leakage current abnormal	Check the insulation resistance of the positive and negative poles of the PV string to the ground; check whether the environment around the inverter is dry; check the grounding of the inverter. If the above is normal, please contact your local agency or service center.
6	Relay fault	If the fault persists, please contact your local agency or service center.
7	Radiator over-temperature	Check whether the radiator of the inverter is blocked, and check whether the ambient temperature of the inverter is too high or too low. If the above is normal and the fault still exists, please contact your local agency or service center.
8	Insulation impedance abnormal	Check the insulation resistance of the positive and negative poles of the PV string to the ground; check whether the environment around the inverter is dry; check whether the grounding point inside the inverter is loose. If the above is normal, please contact your local agency or service center.
9	Fan abnormal	If the fault persists, please contact your local agency or service center.

No.	Fault information	Solution
10	Inner over-temperature	Check whether the radiator of the inverter is blocked, and check whether the ambient temperature of the inverter is too high or too low. If the above is normal and the fault still exists, please contact your local agency or service center.
11	MPPT x over-voltage	Check the system PV string configuration, if the above is normal, please contact your local agency or service center
12	MPPT x over-current	If the fault persists, please contact your local agency or service center
13	Branch x over-current	Check the system PV string configuration, if the above is normal, please contact your local agency or service center
14	Branch x reverse connected	Check whether the branch x is connected in reverse, if the above is normal, please contact your local agency or service center
15	Inner abnormal	If the fault persists, please contact your local agency or service center

 **CAUTION**

If the inverter has an alarm mentioned in Table5-2, please shut down inverter (refer to **4.3 Shut Down Inverter**), 5 minutes later, restart the inverter (refer to **4.2 Start Inverter**). If the alarm status is not removed, please contact our local agency or service center. Before contacting us, please prepare the following information.

1. Inverter S/N.
2. Distributor/ dealer of the inverter (if has).
3. The date of grid-tied power generation.
4. Problem description.
5. Your detail contact information.

6 Stop Running, Dismantle, Discard Inverter

This chapter introduces the dispose way for stop running, dismantling, discarding the inverter.

6.1 Stop Running

Normally, the inverter don't need to be shut down, but when maintenance, it is necessary to shut down the inverter.



Please disconnect the AC and DC connection of inverter according to following procedures successively, or, it may cause human injury or device damage.

- Step 1 Disconnect the external AC switch, and set warning marks at disconnected site to avoid improperly switching on and even cause accident.
- Step 2 Switch off the DC switches on the inverter.
- Step 3 Wait for 30mins at least, ensure that the inner capacitor discharges completely.
- Step 4 Loosen the locked part of PV string connector by D4B wrench, take down the PV string connectors and check that there is no voltage and current in the inverter by the detection equipment.
- Step 5 Dismantle the AC wiring box, measure the wires and ensure that there is no electricity in the AC wires, and then dismantle the AC wires and communication wires.
- Step 6 Install D4B waterproof plug and AC waterproof box.

----End

6.2 Dismantle the Inverter



After the connection among inverter and grid and PV string is completely disconnected and wait for 30mins at least, ensure that the inner capacitor discharge completely and check that there is no voltage and current in the inverter by the detection equipment, and then the inverter can be dismantled.

- Step 1 Disconnect all connection successively in reversed procedures of **3.6 Electrical Connection**.
- Step 2 Dismantle the inverter in reversed procedures of **3.5 Inverter Installation**.
- Step 3 If the inverter will be installed and used in the future, please dismantle the installation holder on the wall or bracket, then pack and store the inverter properly. (see **7.1 Package** and **7.3 Storage**).

----End

6.3 Discard the Inverter

For the inverter that will not to be used, user needs to discard the inverter according to related provision.



The battery, module and other components inside the inverter may pollute the environment, please do corresponding dispose on the basis of related provision.

7 Package, Transportation, Storage

This chapter mainly introduces the package, transportation and storage.

7.1 Package

The package of product is carton. When packing, pay attention to the placing direction requirements. One side of carton, it should print warning icons, including keep dry, handle with care, up, stacking layer limit, etc. The other side of carton, it should print the device model, etc. Print the logo of Kehua company and device name on the front of carton.

7.2 Transportation

Pay attention to the warnings on the carton. Don't impact severely when transportation. In case of damaging device, it should follow the placing direction that shows on the carton. Don't carry device with the objects that inflammable, explosive, or corrosive. Don't put device in the open-air warehouse when transshipment. Leaching and mechanical damage by rain, snow or liquid objects is prohibited.

7.3 Storage

When storing device, it should follow the placing direction that shows on the carton. The gap is 20cm between the carton and ground and the clearance is at least 50cm from carton to wall, heat source, cold source, windows or air inlet.

The storage environment temperature is $-40^{\circ}\text{C} \sim 70^{\circ}\text{C}$. If storing or transporting device beyond the working temperature, before startup, set it alone and wait for the temperature reaches to the range of the working temperature and keep the status more than four hours. In warehouse, It's prohibited that there has poisonous gas, objects that inflammable and explosive, corrosive chemical objects. Besides, it shouldn't have too strong mechanical shaking, impact and strong magnetic field. Under the storage conditions above, the storage period is six months. If it is beyond six months, it has to recheck.

Do not store the inverter in the open air. If it will be stored for a long time, please check the tightness of the inverter and see if there is any abnormal inside the inverter.

A Technical Specifications

A.1 SPI75K-B, SPI80K-B, SPI90K-B and SPI100K-B

Items	SPI75K-B	SPI80K-B	SPI90K-B	SPI100K-B
DC input				
Max. input voltage	1100V			
Min. input voltage/startup voltage	200V/250V			
Rated input voltage	600V			
MPPT voltage range	200V~1000V			
MPPT voltage with full load	500V~850V			
MPPT quantity	9 (4 routes, 6 routes and 7 routes are optional)	9 (6 routes is optional)		
Max. PV quantity of each MPPT	2			
Max. input current	9×30A (4×30A, 6×40A, 7×30A are optional)	9×30A (6×40A is optional)		
Max. DC short-circuit current	9×50A (4×50A, 6×50A, 7×50A are optional)	9×50A (6×50A is optional)		
AC output				
Rated output power	75kW	80kW	90kW	100kW
Max. output power	75kW	88kW	99kW	110kW

Items	SPI75K-B	SPI80K-B	SPI90K-B	SPI100K-B
Max. output apparent power	75kVA	88kVA	99kVA	110kVA
Rated output current	108.3A	115.5A	129.9A	144.4A
Max. output current	108.3A	127A	142.9A	158.8A
Rated grid voltage	3/N/PE, 230V/400V			
Grid voltage range	320V~460V			
Rated grid frequency	50Hz/60 Hz			
Grid frequency range	45Hz~55Hz/55Hz~65Hz			
Total current wave distortion rate	<3% (under rated power)			
DC component	<0.5% In			
Power factor	>0.99 (under rated power)			
Power factor range	0.8 ahead ~0.8 lag			
Output phase	3			
Efficiency				
Max. efficiency	98.7%			
Europe efficiency	98.5%			
General features				
Dimension (W×H×D)	1030mm×610 mm×345 mm			
Weight	80kg			
Installation way	Wall-mounted			
Isolation type	No transformer			
Protection grade	IP66			
Self-consumption at night	<2W			
Operation temperature range	-35℃~+60℃			
Operation humidity range	0~100%			

Items	SPI75K-B	SPI80K-B	SPI90K-B	SPI100K-B
Heat dissipation way	Smart forced wind-cooling			
Max. operation altitude	4000m (>3000m decrease rate power)			
Display	LED, Bluetooth +APP			
Communication	RS485/GPRS (optional) / WIFI (optional)			
DC terminal type	D4B			
AC terminal type	OT terminal (Max. cross-sectional area is 240mm ²)			

- Specifications are subject to change without prior notice.

A.2 SPI110K-B, SPI125K-B, SPI136K-BHV and SPI150K-BHV

Items	SPI110K-B	SPI125K-B	SPI136K-BHV	SPI150K-BHV
DC input				
Max. input voltage	1100 V			
Min. input voltage/startup voltage	200V/250V			
Rated input voltage	600V		780V	
MPPT voltage range	200V~1000V			
MPPT working voltage with full load	500V~850V		600V~850V	
MPPT quantity	9 routes (6 routes is optional)		10 routes (6 routes is optional)	
Max. PV quantity of each MPPT	2			
Max. input current	9×30A (6×40A is optional)		10×30A (6×40A is optional)	
Max. DC short-circuit current	9×50A (6×50A is optional)		10×50A (6×50A is optional)	
AC output				
Rated output power	110kW	125kW	136kW	150kW
Max. output power	121kW	137.5kW	149.6kW	165kW
Max. output apparent power	121kVA	137.5kVA	149.6kVA	165kVA

Items	SPI110K-B	SPI125K-B	SPI136K-BHV	SPI150K-BHV
Rated output current	158.8A	180.5A	145.4A	160.4A
Max. output current	174.7A	198.5A	159.9A	176.4A
Rated grid voltage	3/N/PE, 230V/400V		3/PE, 310V/540V	
Grid voltage range	320V~460V		432V~621V	
Rated grid frequency	50Hz/60Hz			
Grid frequency range	45Hz~55Hz/55Hz~65Hz			
Total current wave distortion rate	<3% (under rated power)			
DC component	<0.5% In			
Power factor	>0.99 (under rated power)			
Power factor range	0.8 ahead~0.8 lag			
Output phase	3			
Efficiency				
Max. efficiency	98.7%		99.0%	
Europe efficiency	98.5%		98.7%	
General				
Dimension (W×H×D)	1030mm×610mm×345mm			
Weight	80kg			
Installation way	Wall-mounted			
Isolation type	No transformer			
Protection grade	IP66			
Self-consumption at night	<2W			
Operation temperature range	-35℃~+60℃			
Operation humidity range	0~100%			
Heat dissipation way	Smart forced wind-cooling			

Items	SPI110K-B	SPI125K-B	SPI136K-BHV	SPI150K-BHV
Max. operation altitude	4000m (>3000m decrease rate power)			
Display	LED, Bluetooth +APP			
Communication	RS485/GPRS (optional)/WIFI (optional)			
DC terminal type	D4B			
AC terminal type	OT terminal (Max. cross-sectional area is 240mm ²)			

- Specifications are subject to change without prior notice..

B Quality Assurance

If the device fault in guarantee period, Kehua Company will maintenance it free or replace new product.

Evidence

In guarantee period, user needs to show the purchase invoice of the product, and the trademark on the product must be clearly visible, or, Kehua Company have right to refuse the quality assurance.

Condition

- The replaced product must be returned to Kehua Company to dispose.
- Reasonable time should be reserved for Kehua Company to maintain the fault device.

Disclaimer

If any situation below occurs, Kehua Company have right to refuse the quality assurance.

- Beyond the free quality assurance period.
- Damaged by transportation.
- Improper installation, transformation or use.
- Used in the harsh environment that not allowed in the user manual.
- Damaged by installation, maintenance, transformation or dismantling of other company server.
- Damaged by using component or software of non-standard or other company except Kehua Company.
- Beyond the installation and use range of related national standard.

- Damage caused by abnormal nature environment.

If the fault is caused by above situation and user requires to maintain it, we can provide paid maintenance service after our service organization decided.

To improve users' satisfaction continuously, our product and user manual is upgrading. If the user manual has difference with product, it may be caused by the version difference, please take the actual product as standard. If any question, please contact our company.

Software authorization

- It is prohibited to use part or whole data of the hardware or software of Kehua Company in any way for commercial purpose.
- It is prohibited to decompile, decrypt or destroy the original program design of the software developed by Kehua Company.

C Acronyms and Abbreviations

A

AC Alternating Current

L

LCD Liquid Crystal Display

LED Light-emitting Diode

M

MPPT Maximum Power Point Tracking

P

PE Protective Earthing

PV Photovoltaic

R

RS485 Recommend Standard485

U

USB Universal Serial Bus



XIAMEN KEHUA DIGITAL ENERGY TECH CO., LTD.

ADD: Room 208-38, Hengye Building, No. 100 Xiangxing Road, Torch
High-tech Zone (Xiang'an) Industrial Zone, Xiamen, China (361000)
TEL: 0592-5160516 (8 lines)
FAX: 0592-5162166
[Http://www.kehua.com](http://www.kehua.com)



Technical Support

4402-03569 004