

SK6610M

310/315/320W

60 CELLS

MONO 5BB

High Efficiency Module



PRODUCT FEATURES



High Efficiency

Output efficiency up to 19.7%
0~3% positive power tolerance
5-busbar has better collected current capability



Excellent Low-Irradiance

Well generation capacity and temperature stability especially in faint lighting conditions



Anti-PID Design

Products satisfy IEC62804 tests by anti-PID cell and module technology



Harsh Environment Adaptability

Salt mist resistance
Ammonia resistance
Dust and sand resistance



Robust Mechanical Durability

Strong mechanical durability of 5400Pa snow load, 2400Pa wind load



COMPANY PROFILE

Akcome Optronics is a leading manufacturer and service provider of professional photovoltaic cells and modules that can be widely utilized in residence, commerce and ground photovoltaic plant. Founded in 2010, and became wholly-owned subsidiary of Jiangsu Akcome Science & Technology Co., Ltd. (002610).

Akcome Optronics provides PV products with exceptional power output and reliability by integrating rigorous design, advanced production technology and fully automatic production equipment. Strict quality control and test standards confirm its pursuit of zero-defect output.

LINEAR PERFORMANCE WARRANTY



Product warranty on materials and workmanship



Linear power output warranty

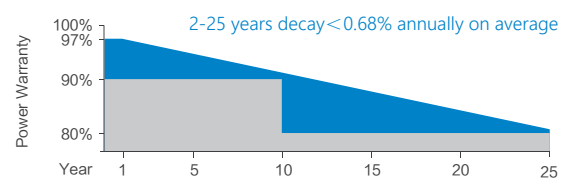

CERTIFICATES

IEC 61215 / IEC 61730

ISO 9001: 2015

Quality Management System

ISO 14001: 2015

Environmental Management System

OHSAS 18001: 2007

Occupational Health & Safety Management System

*Certification requirements vary in different markets, please consult with Akcome Optronics sales team for appropriate certification.



SK6610M 310/315/320W

ELECTRICAL PARAMETERS @ STC

Parameter	310	315	320
Max. Power Output Pmax (W)	310	315	320
Power Tolerance	0~+3%	0~+3%	0~+3%
Max. Power Voltage Vmp (V)	32.3	32.4	32.6
Max. Power Current Imp (A)	9.60	9.72	9.82
Open Circuit Voltage Voc (V)	40.1	40.3	40.5
Short Circuit Current Isc (A)	10.09	10.20	10.31
Module Efficiency (%)	19.1	19.4	19.7

*STC (Standard Test Condition): Irradiance 1000W/m², Cell Temperature 25°C, Air Mass 1.5

ELECTRICAL PARAMETERS @ NOCT

Parameter	229.2	232.7	236.7
Max. Power Output Pmax (W)	229.2	232.7	236.7
Max. Power Voltage Vmp (V)	30.05	30.22	30.37
Max. Power Current Imp (A)	7.63	7.70	7.79
Open Circuit Voltage Voc (V)	37.01	37.19	37.38
Short Circuit Current Isc (A)	8.16	8.25	8.34

*NOCT(Nominal Operating Cell Temperature): Irradiance 800W/m², Ambient Temperature 20°C, Wind Speed 1m/s

TEMPERATURE COEFFICIENTS

Temperature Coefficients of Pmp	-0.39%/°C
Temperature Coefficients of Voc	-0.30%/°C
Temperature Coefficients of Isc	+0.050%/°C

MECHANICAL PARAMETERS

Cell Type	Mono 156.75x156.75mm
Number of Cells	60pcs(6x10)
Dimensions (L*W*H)	1640x992x35mm
Weight	18.5kg
Frame	Anodised Aluminum
Junction Box	IP67, 3 bypass diodes
Cable, Length	4.0mm ² , 900mm

OPERATING CONDITION

Maximum System Voltage(V)	1000(DC)
Operating Temperature(°C)	-40~+85
Max. Wind Load / Snow Load(pa)	2400/5400
Max. Over Current(A)	15
Application Class	Class A
Fire Rating	Class C
NOCT(°C)	45±2

PACKAGE INFORMATION

Truck 9.6m / 13m / 17.5m	670 / 938 / 1573pcs
Container 20'GP / 40'GP / 40'HQ	360 / 840 / 896pcs
Quantity / Pallet	30pcs

ASSEMBLY DRAWING (Unit: mm)

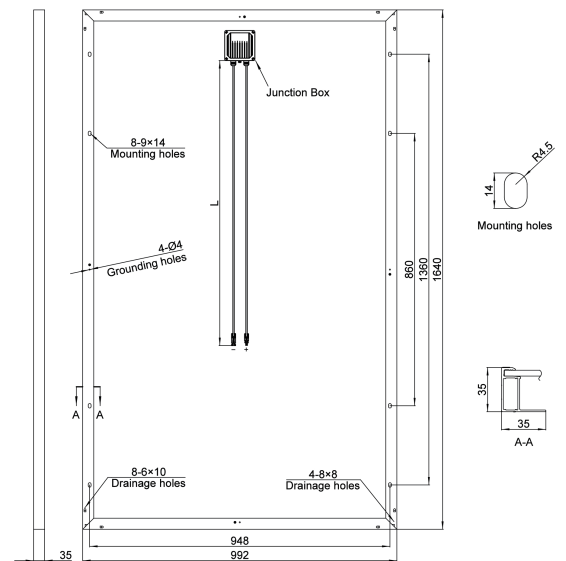

I-V CURVES / SK6610M-320

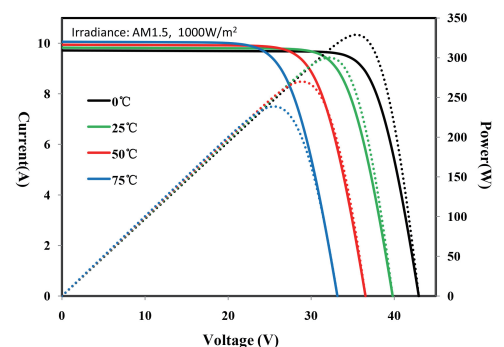
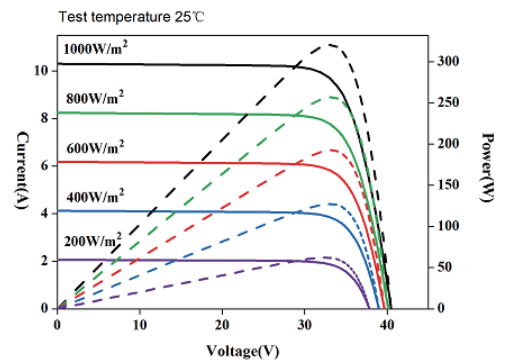

AKCOME OPTRONICS SCIENCE & TECHNOLOGY CO.,LTD.

Add: No. 110 Jintang Road, Zhangjiagang economic and Technological Development Area, Jiangsu P.R. China

Tel: 400-101-7000

Email: modulesales@akcome.com

www.akoptronics.com

